

SERVICE MANUAL





MARVEL GUARDIANS OF THE GALAXY



[IMPORTANT]

- ▶ Please read the manual carefully and keep it in mind before using this machine
- ▶ Put this manual within touch of your reference in anytime.

ISSUE DATE: Nov. 14, 2023

PRODUCT INFO	PART INFO	SUPPORT INFO	NEW PRODUCT INFO
			

※ QR(SUPPROT) - Leaflets, manuals, solution(error code, trouble shooting document, watch&solve)

PRECAUTIONS FOR USE

The following safety precautions are given throughout this manual. They must be strictly followed to protect those who install, use or maintain this product as well as to protect players, visitors and property.

For safety reasons.

- The following suggestions should be adhered to:



Disregarding could result in serious injury.



Disregarding could result in injury or product damage.

- The following graphic suggestions describe the types of precautions to be followed.



Indicates a care should be taken.



Forbidden.



Indicates a matter which must be performed.

- **Precautions to be followed:**

Certain procedures require a qualified in-shop maintenance person or industry specialist.

For such instructions, a qualified person must take care of the jobs.

- Otherwise an electric shock, machine trouble or a serious accident may result.
- Replacing the machine parts, inspecting and maintaining the machines and troubleshooting must be assigned only to a qualified in-shop maintenance person or industry specialist. This booklet gives instructions that hazardous jobs in particular must be handled by an industry specialist. Qualified in-shop maintenance person and industry specialist are defined as follows.

Qualified in-shop maintenance person

- A service staff shall have experience in operations of game machines. The staff shall be responsible for assembly, installation, inspection and maintenance of the machine.

Industry specialist

- An industry specialist must be engaged in designing, manufacturing, inspecting and servicing amusement machines. He or she must have an education in electrical, electronic and mechanical engineering and routinely maintain and repair amusement machines.

PRECAUTIONS FOR USE

WARNING

Be sure to consult an industry specialist when setting up, moving or transporting this product.

- This product should not be set up, moved or transported by any one other than an industry specialist.
- When installing this product, set the 4 leg levelers evenly on the floor and make sure that the product is installed stably in a horizontal position. Unstable installation may result in injury or accident.
- When installing this product, do not apply undue force on movable parts. Otherwise, injury and accident may result, or the product may be damaged.

The machine for indoor usage only does not install outside.



Do not set the game machine up near emergency exits.



Protect the game machine from:

- Rain or moisture.
- Direct sunlight.
- Direct heat from air-conditioning and heating equipment, etc..
- Hazardous flammable substances.
- Otherwise an accident or malfunction may result.



Do not place containers holding chemicals or water on or near the game machine.



Do not place objects near the ventilating holes.



Do not bend the power cord by force or place heavy objects on it.



Never plug or unplug the power cord with wet hands.



Never unplug the game machine by pulling the power cord.



CAUTION

Be sure to use indoor wiring within the specified voltage requirements. For extension cord, use the specified rating or more.

Be sure to use the attached power cord.

Never plug more than one cord at a time into the electrical receptacle.



Do not lay the power cord where people walk through.



Be sure to ground this product.



Do not exert excessive force when moving the machine.



For proper ventilation, keep the game machine 100mm(4") away from the walls.

Do not alter the system related dipswitch settings.

PRECAUTIONS FOR USE

WARNING

If there is any abnormality such as smoke, bad smell or abnormal noise being emitted from the machine, immediately turn OFF the main power switch and unplug the power cord from the receptacle to stop operating it. 

- Using the machine in abnormal conditions could result in fire or accidents.

In case of abnormality

1. Turn OFF the main power switch.
2. Unplug the power cord from the receptacle.
3. Contact your nearest dealer.

Do not leave the power cord plugged in improperly or covered with dust. 

- Doing so could result the power cord periodically.

CAUTION

Do not use this product anywhere other than industrial areas. 

- Using in a residential area or an area next to a residential area could affect signal reception of radios, television sets, telephones and etc..
- Do not give shock the surface of glass products.

- Please do not play this game if
 - When you do drinking;
 - When your physical condition is not normal;
 - When you are in pregnancy;
 - When you have on a pulse controller;
 - When you have recently experienced a cramp or fainting away while watching TV.
- Avoid excessive force/shock while playing/moving the game.
- While do games, pay attention to surrounding.

Do not plug or unplug the power cord with wet hands. 

In handling the power cord, follow the instructions below. 

- | | |
|---|--|
| • Do not damage the power cord. | • Do not modify the power cord. |
| • Do not bend the power cord excessively. | • Do not twist the power cord. |
| • Do not heat the power cord. | • Do not pull the power cord. |
| • Do not bind the power cord. | • Do not stand on the power cord. |
| • Do not sandwich the power cord. | • Do not drive a nail into the power cord. |

If the power cord or power plug becomes damaged, stop using the machine immediately and ask your nearest dealer to replace the parts.

*** Electromagnetic wave may cause unexpected noise from speaker.**

PRECAUTIONS FOR USE

WARNING

Be sure to turn OFF the main power switch and unplug the power cord from the receptacle before inspecting or cleaning the machine.



When replacing parts, be sure to use parts of the correct specifications. Never use parts other than the specified ones.



Opening inside the machine shall be done by machine specialist only as high electric current is being sent inside. For game machine with monitor, a care should be taken while opening its back door. If not, a damage to the inside parts or the monitor may occur.



If the sub power switch of the service panel is turned OFF without turning OFF the main power switch of the power supply unit, some parts in the units remain live. When opening the back door, be sure to turn OFF the main power switch and unplug the power cord from the receptacle.



Strictly refrain from disassembly and repair of parts which are not indicated in this manual, as well as settings and remodeling.



To clean the game machine, wipe it with a soft cloth dampened in a neutral detergent.

- Using thinner or other organic solvent or alcohol may decompose the material.
- Electrical shock or equipment failure could be caused by water entering the inside of the machine.

CAUTION

Components in the game are sensitive to vibrations and impact. Care should be used when moving and transporting the game machine.



Be sure not to let the machine tip over.

Before moving the machine, be sure to turn OFF the main power switch, unplug the power cord from the receptacle and remove the power cord from the machine.



Before moving take the machine, off the levelers and move it on the casters.

Avoid excessive force while moving the machine.

.....

PRECAUTIONS IN HANDLING

- When setting up, inspecting, maintaining, moving or transporting this product, follow the procedures and instructions set forth in this manual and perform such work safely.
- Do not set up, handle, inspect, maintain, move or transport this product under conditions equivalent to the condition of "WARNING" or "CAUTION" specified in this manual.
- If a new owner is to have this product as a result of transfer, and etc., be sure to give this manual to the new owner.

PRÉCAUTION D'EMPLOI

Les consignes de sécurité suivantes sont données dans ce manuel. Elles doivent être strictement suivies pour protéger ceux qui les installent. Utiliser ou entretenir ce produit pour la sécurité des utilisateurs, des visiteurs et des biens.

Pour des raisons de sécurité.

- **Les suggestions suivantes doivent être respectées:**

ATTENTION

Le non-respect peut entraîner des blessures graves.

PRUDENCE

Le non-respect peut entraîner des blessures ou des dommages au produit.

- **Les suggestions graphiques suivantes décrivent les types de précautions à prendre.**



Indique qu'attention est requise.



Interdit.



Indique que quelque chose doit être effectuée.

- **Les précautions à prendre :**

Certaines procédures exigent une personne de maintenance qualifiée en atelier ou un spécialiste de l'industrie. Pour ces instructions, une personne qualifiée doit prendre soin des travaux.

- Sinon, un choc électrique, un dysfonctionnement de la machine, ou un accident grave peut en résulter.
- Remplacement des pièces de machines, l'inspection et la maintenance des machines, et le dépannage doit être attribué qu'à une personne de maintenance qualifiée en atelier ou spécialiste de l'industrie. Cette brochure donne des instructions que les emplois dangereux, en particulier, doivent être traités par un spécialiste de l'industrie. La personne de maintenance qualifiée en atelier et le spécialiste de l'industrie sont définis comme suit.

La personne de maintenance qualifiée en atelier

- Un personnel de service doit avoir de l'expérience dans les opérations de machines de jeux. Le personnel est responsable pour l'assemblage, l'installation, l'inspection et l'entretien de la machine.

Le spécialiste de l'industrie

- Un spécialiste de l'industrie doit être engagé dans la conception, la fabrication, l'inspection et l'entretien des appareils d'amusement.
Il ou elle doit avoir une formation en génie électrique, électronique et mécanique, et de maintenir régulièrement et de réparer les appareils d'amusement.

PRÉCAUTION D'EMPLOI

ATTENTION

Si il y a une anomalie comme fumée, mauvaise odeur ou bruit anormal émis par la machine,  couper immédiatement l'interrupteur principal et débranchez le câble d'alimentation de la prise pour arrêter son fonctionnement.

- L'utilisation de l'appareil dans des conditions anormales peut provoquer un incendie ou un accident.

En cas d'anomalie

1. Mettez l'interrupteur principal sur ARRÊT.
2. Débranchez le câble d'alimentation de la prise.
3. Contactez votre revendeur le plus proche.

Ne pas brancher le câble d'alimentation incorrectement ou le laisser être recouvert de poussière. 

Cela pourrait nuire le câble d'alimentation.

PRUDENCE

Ne pas utiliser ce produit ailleurs que dans les zones industrielles. 

- L'utiliser dans une zone résidentielle ou d'une zone à côté d'un quartier résidentiel pourrait nuire à la réception des radios, téléviseurs, téléphones, etc.
- Ne donnez pas de choc à la surface d'un produit en verre.

- S'il vous plaît ne pas jouer à ce jeu.
 - Quand vous buvez;
 - Lorsque votre condition physique n'est pas normale;
 - Lorsque vous êtes dans une période de grossesse;
 - Lorsque vous avez un contrôleur d'impulsion;
 - Lorsque vous avez récemment subi une crampe ou évanouissement en regardant la télévision.
- Évitez une force excessive / un choc pendant la lecture / de déplacer le jeu.
- Quand vous jouez les jeux, faites attention aux alentours.

Ne pas brancher ou débrancher le câble d'alimentation avec les mains mouillées. 

Dans la manipulation du câble d'alimentation, suivez les instructions ci-dessous. 

- | | |
|--|---|
| • Ne pas endommager le câble d'alimentation. | • Ne pas modifier le câble d'alimentation. |
| • Ne pas plier le câble d'alimentation de manière excessive. | • Ne tordez pas le câble d'alimentation. |
| • Ne pas chauffer le câble d'alimentation. | • Ne tirez pas sur le câble d'alimentation. |
| • Ne pas lier le câble d'alimentation. | • Ne montez pas sur le câble d'alimentation. |
| • Ne pas prendre en sandwich le câble d'alimentation. | • Ne pas mettre un clou dans le câble d'alimentation. |

Si la fiche du câble d'alimentation ou est endommagé, cessez immédiatement d'utiliser la machine et demandez à votre revendeur le plus proche de remplacer les pièces.

PRÉCAUTION D'EMPLOI

⚠ ATTENTION

Assurez-vous de consulter un spécialiste de l'industrie lors de la mise en place, du déplacement ou le transport de ce produit.

- Ce produit ne doit pas être mis en place, déplacé ou transporté par une quelconque autre qu'un spécialiste de l'industrie.
- Lors de l'installation de ce produit, installez 4 niveleurs de pieds uniformément sur le sol et assurez-vous que le produit est installé de façon stable dans une position horizontale. Une installation instable peut entraîner des blessures ou un accident.
- Lors de l'installation de ce produit, ne pas appliquer une force excessive sur les pièces mobiles. Sinon, des blessures et des accidents peuvent y résulter, ou le produit peut être endommagé.

La machine pour une utilisation en intérieur uniquement, ne pas installer à l'extérieur.



N'installez pas la machine de jeu près des issues de secours.



Protéger la machine de jeu de:



- L'humidité ou la pluie.
- La lumière directe du soleil.
- La chaleur directe de la climatisation et du chauffage, etc...
- Des substances inflammables dangereuses.
- Sinon, un accident ou un dysfonctionnement.

Ne pas placer les récipients contenant des produits chimiques ou de l'eau sur ou près de la machine de jeu.



Ne placez pas d'objets à proximité des orifices de ventilation.



Ne pas plier le cordon d'alimentation par la force ou de placer des objets lourds au-dessus.



Ne jamais brancher ou débrancher le cordon d'alimentation avec les mains mouillées.



Ne jamais débrancher la machine de jeu en tirant le câble d'alimentation.



⚠ PRUDENCE

Veillez à utiliser le câblage intérieur selon les exigences de tension spécifiées. Pour une rallonge, utilisez la notation spécifiée ou plus.

Veillez à utiliser le cordon d'alimentation fourni.

Ne jamais brancher plus d'un cordon à la fois dans la prise électrique.



Ne pas poser le cordon d'alimentation où les gens marchent à travers.



Soyez sûr de mettre à la terre ce produit.



Ne pas exercer une force excessive lors du déplacement de la machine.



Pour une ventilation correcte, garder la machine de jeu 100mm (4 ") loin des murs.

Ne pas modifier les réglages des commutateurs DIP liées au système.

PRÉCAUTION D'EMPLOI

ATTENTION

Veillez à éteindre l'interrupteur d'alimentation principale et débranchez le cordon d'alimentation de la prise avant d'inspecter ou de nettoyer la machine. 

Lors du remplacement des pièces, veillez à utiliser une partie des spécifications correctes. Ne jamais utiliser de pièces autres que celles spécifiées. 

L'ouverture à l'intérieur de la machine doit être effectuée par le spécialiste de la machine seulement, comme le courant électrique élevé est transmis à l'intérieur. Pour la machine de jeu avec le moniteur, un soin doit être pris lors de l'ouverture de sa porte arrière. Si non, une détérioration des pièces à l'intérieur ou à l'écran peut se produire. 

Si l'interrupteur secondaire du panneau de service est éteint sans éteindre le commutateur d'alimentation principale de l'unité d'alimentation, certaines parties dans les unités restent sous tension. Lors de l'ouverture de la porte arrière, veillez à éteindre l'interrupteur d'alimentation principale et débranchez le cordon d'alimentation de la prise. 

Il est strictement conseillé de s'abstenir de démonter et de réparer des pièces qui ne sont pas indiqués dans ce manuel, ainsi que les paramètres et le remodelage. 

Pour nettoyer la machine de jeu, l'essuyer avec un chiffon doux imbibé avec un détergent neutre.

- L'utilisation plus mince d'un autre solvant organique ou de l'alcool peut décomposer le matériel.
- Un choc électrique ou une défaillance de l'équipement pourraient être causés par la pénétration de l'eau à l'intérieur de la machine.

PRUDENCE

Les composants de la machine de jeu sont sensibles aux vibrations et aux chocs. Il faut faire attention lors du déplacement et le transport de la machine de jeu. 

Veillez à ne pas laisser la machine se renverser.

Avant de déplacer la machine, veillez à éteindre l'interrupteur d'alimentation principale, débranchez le cordon d'alimentation de la prise et débranchez le cordon d'alimentation de la machine. 

Avant de déplacer la machine, la mettre hors des niveleurs et le déplacer sur les roulettes.

Éviter une force excessive lors du déplacement de la machine.

.....

PRÉCAUTIONS LORS DU MANIEMENT

- Lors de la mise en place, l'inspection, l'entretien, déplacement ou le transport de ce produit, suivez les procédures et les instructions énoncées dans ce manuel et effectuer ce travail en toute sécurité.
- Ne pas mettre en place, manipuler, inspecter, entretenir, déplacer ou transporter ce produit dans des conditions équivalentes à l'état de "ATTENTION" ou "PRUDENCE" spécifiée dans ce manuel.
- Si un nouveau propriétaire obtient ce produit à la suite d'un transfert, etc., soyez sûr de donner ce manuel au nouveau propriétaire.

- CONTENTS

	PAGE
1 SPECIFICATION AND DIMENSION	
1) DIMENSION	p02
2) SPECIFICATION	p02
3) STICKER LOCATION	p03
2 INSTALL INFORMATION	
1) INSTALLATION SPACE	p04
2) MAINTAIN PRODUCT FLATNESS	p04
3) IMPORTANCE	p04
3 COMPONENTS	p05
4 INSTALL	
1) HOW TO INSTALL (BILLBOARD)	p06
5 SETUP SETTINGS	
1) OPERATING OPTIONS	p10
2) PROGRAM SETTING	p10
3) CLEAR MODE	p15
4) BOOKKEEPING	p15
5) FACTORY-SETTING	p15
6) TEST MODE	p16
7) CALIBRATION MODE	p18
[SENSOR CALIBRATION MANUAL]	p19
8) ERROR CODE	p21
6 MAINTENANCE	p22
7 SOLUTION	
1) ERROR CODE	p23
8 TROUBLESHOOTING	p24~32
[Er.02, Er.03, Er.11, Er.13, Er.21, Er.31, Er.32, Er.33, Er.34, Er.35, Er.41]	
[Er.42, Er.51, Er.61, Er.62, Er.63, Er.64, Er.80, HELP, Er22]	
9 EXPLODED VIEW	
▶ DETAILED EXPLANATION	p33~48
10 PCB CONNETCOR LOCATION	p49
11 BLOCK DIAGRAM	p51
12 WARRANTY ITEM	p58

1 SPECIFICATION AND DIMENSION

1) DIMENSION

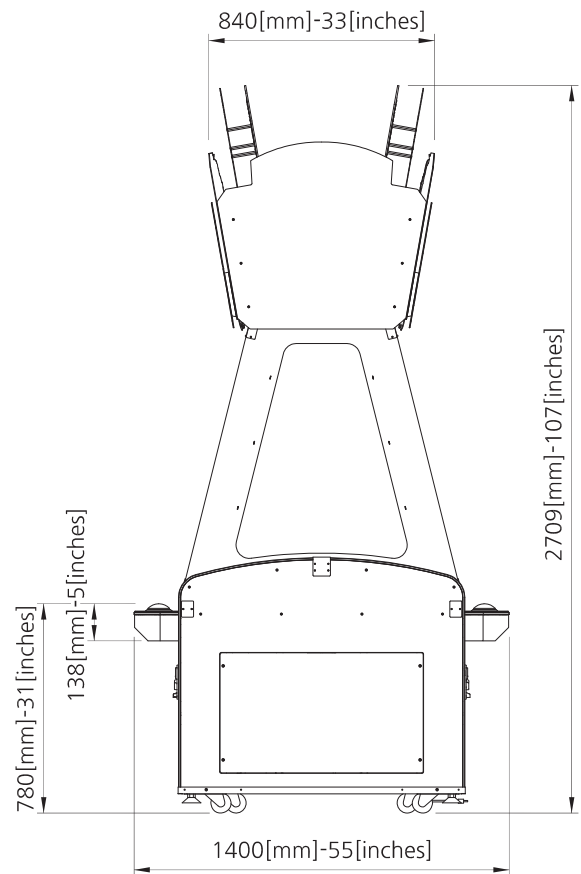
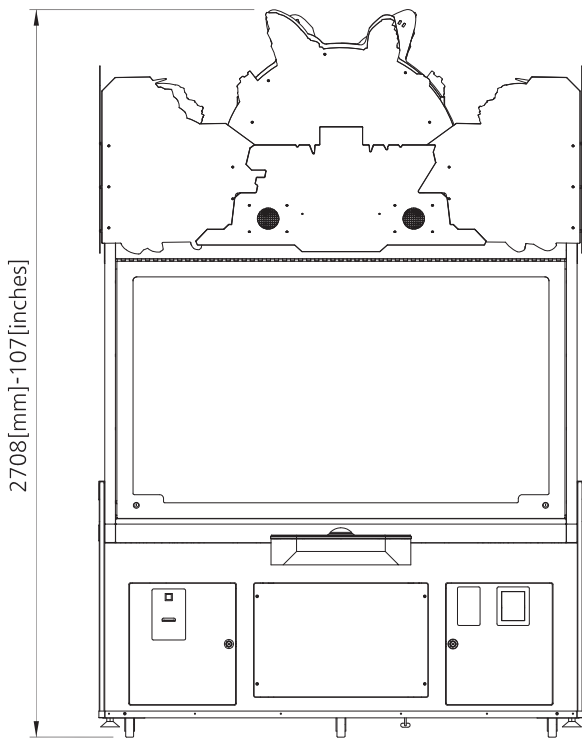
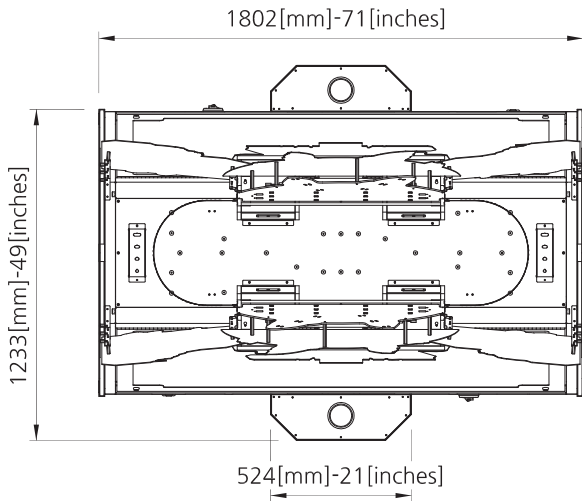



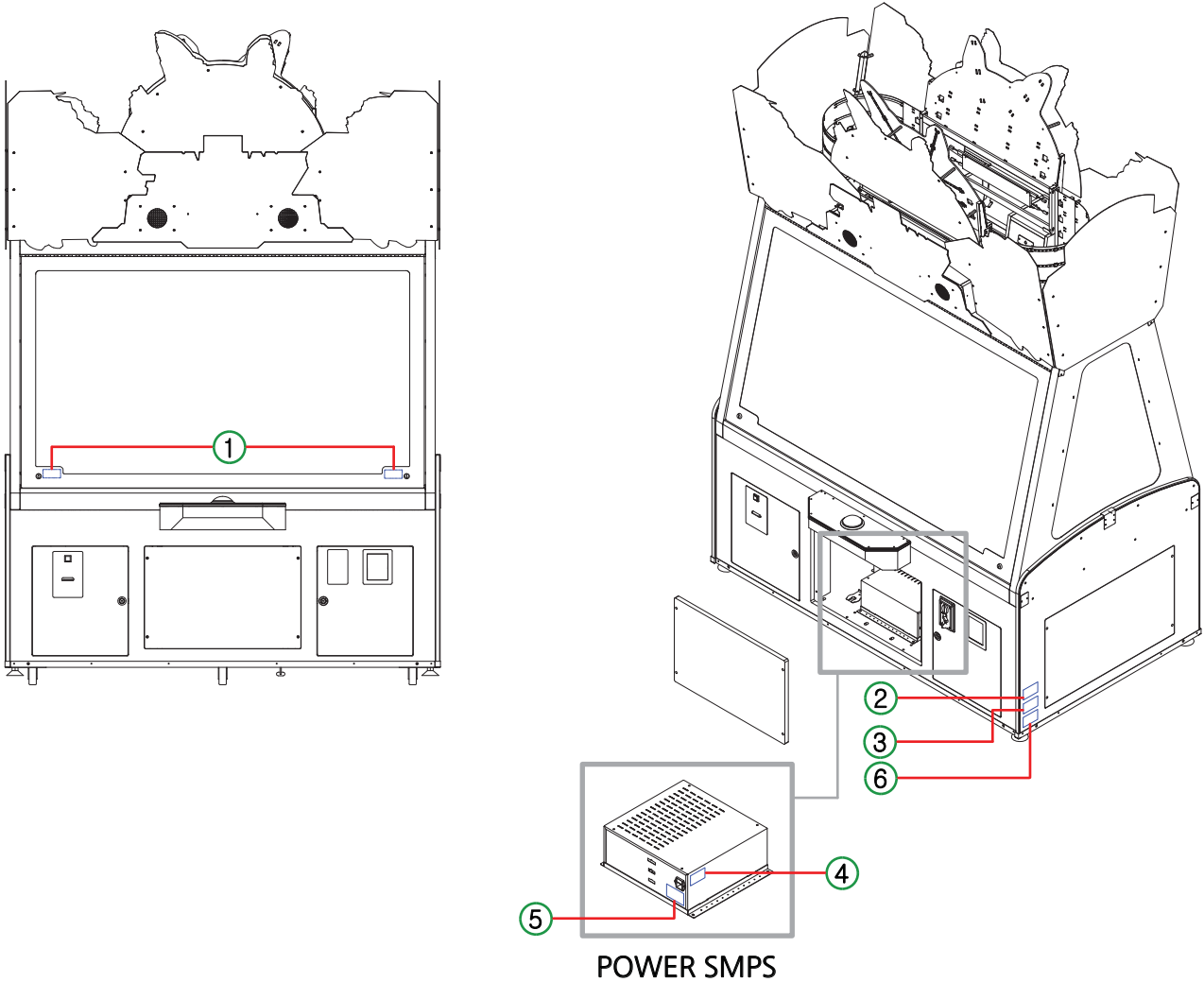

2) SPECIFICATION

ITEM	DETAILS	
VOLTAGE	AC 120V	AC 230V
FREQUENCY RANGE	60 Hz	50/60 Hz
CONSUMPTION	520 W	
INSTALL DIMENSION(W*D*H)	1802*1233*2708 mm , 71*49*107 inch	
PACKING DIMENSION(W*D*H)	1900*1190*2250mm , 75*47*89 inch	
WEIGHT(kg), PACKING WEIGHT(kg)	445kg, 480kg	
CERTIFICATION	ETL	-
※ NOTE : This product is a free bolt product.(AC 120-230V)		

3) STICKER LOCATION

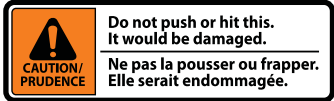

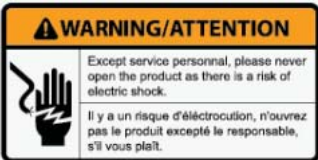
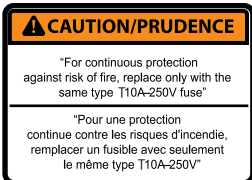
POWER SMPS

▼ 1	▼ 2	▼ 3
		
▼ 4	▼ 5	▼ 6
		

*** AVOID INSTALLING THE PRODUCT IN A PLACE WITH A LOT OF SUNLIGHT. IT CAN BE PROBLEMATIC FOR THE OPERATION OF THE PRODUCT.**

1) INSTALLATION SPACE

- ※ Maintenance zone & Play zone distance maintenance
: should have at least 2500 mm * 2500mm each

2) MAINTAIN PRODUCT FLATNESS

- ※ After installation is complete
: adjust the 4 adjuster so that the product is stably leveled.





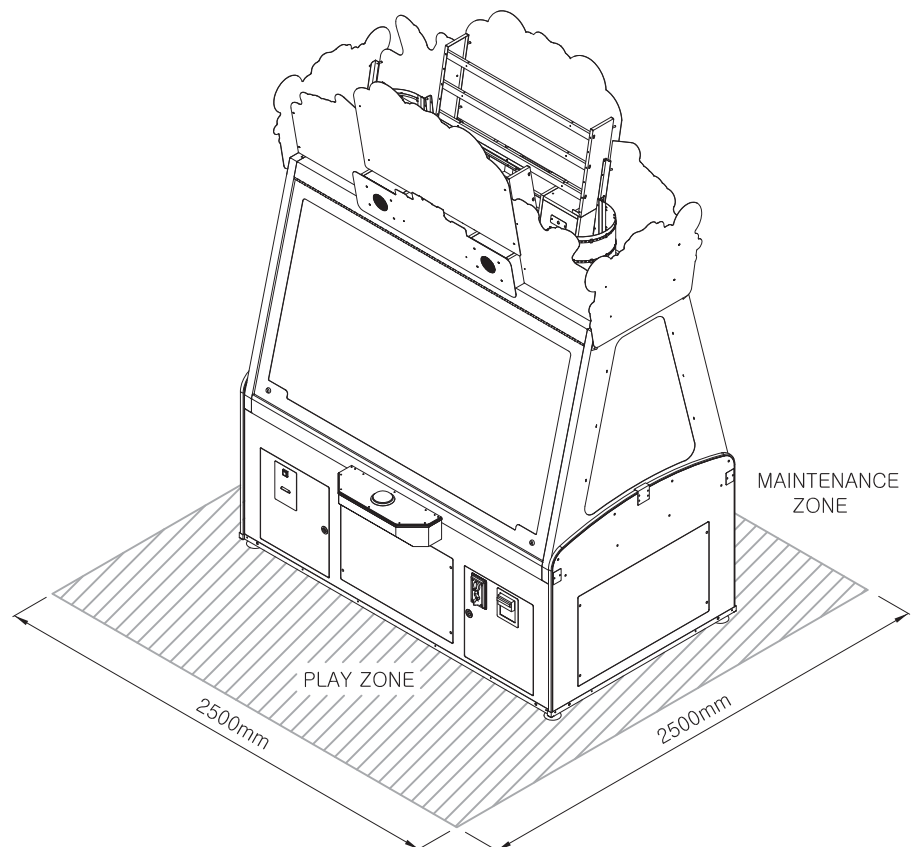



3) IMPORTANCE

- ※ This product should be indoor use and out of direct sunlight.



3 COMPONENTS

NO	PART NAME	Q'TY	SPARE	NO	PART NAME	Q'TY
1	AC POWER CORD	1		10	BILLBOARD TITLE ACRYL FIX SHAFT [MGOT0PRO003]	5
2	KEY 7001	2		11	BILLBOARD FRONT ACRYL FIX SHAFT [MGOT0PRO001]	6
3	WRENCH 3,4,5 mm	1 EACH		12	BILLBOARD SIDE ACRYL FIX SHAFT [MGOT0PRO002]	12
4	BALL	10		13	MANUAL	1
5	TH_NI M4*6	86	8			
6	TH_NI M4*10	22	4			
7	TH_NI M4*16	44	8			
8	TH_NI M4*16	6	2			
9	TH_NI M4*10	6	2			

▼ 1	▼ 2	▼ 3	▼ 4	▼ 5, 6, 7, 8, 9	▼ 10
					
▼ 11	▼ 12	▼ 13			
					

4 INSTALL

1) HOW TO INSTALL(BILLBOARD)

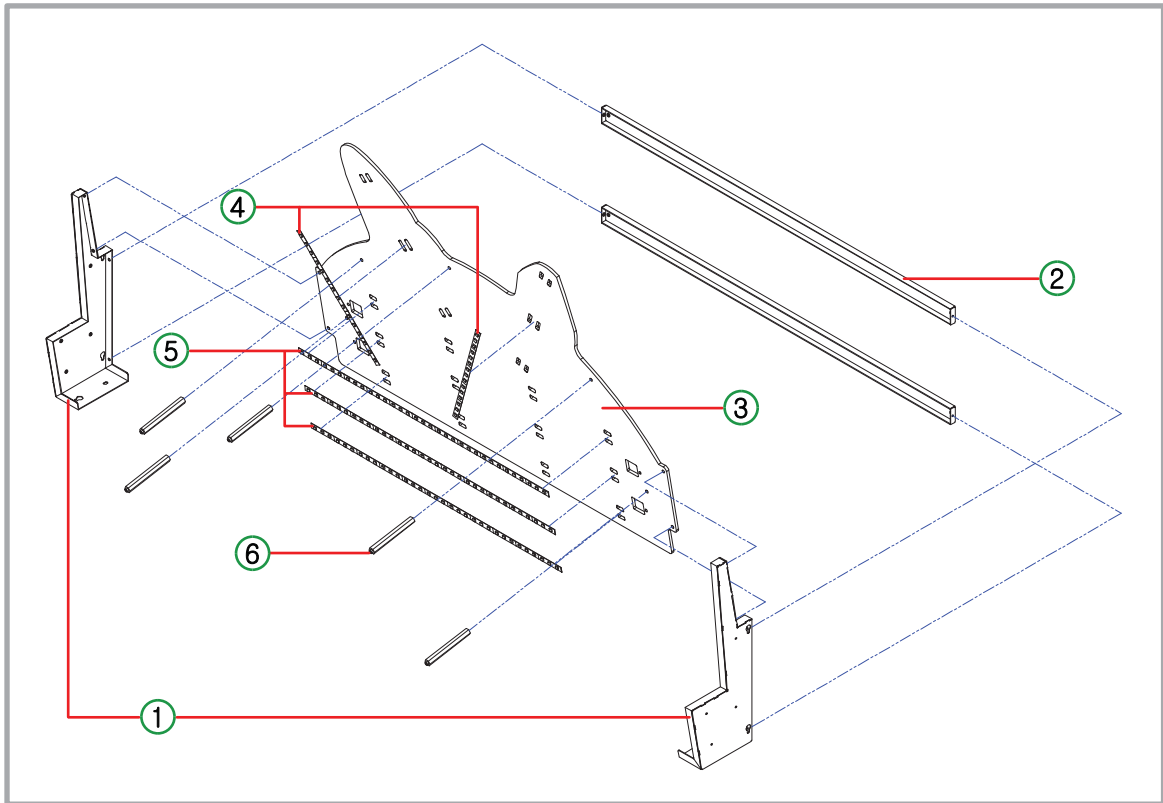

NO	PROCESS	ITEM	Q'TY	BOLT	SPEC	Q'TY
1		BILLBOARD TITLE FIX BKT-L, R	2			
2	ASSEMBLE	BILLBOARD TITLE LED BKT	2	TH NI	M4*6L	4
3	ASSEMBLE	BILLBOARD TITLE LED FOMAX	1	TH NI	M4*10L	4
4	ASSEMBLE	FLEX_T5050_WHITE_250_NWP_L_15	2			
5	ASSEMBLE	FLEX_T5050_WHITE_250_NWP_L_15	3			
6	ASSEMBLE	BILLBOARD TITLE ACRYL FIX SHAFT [MGOTOPRO003]	5	TH NI	M4*10L	5

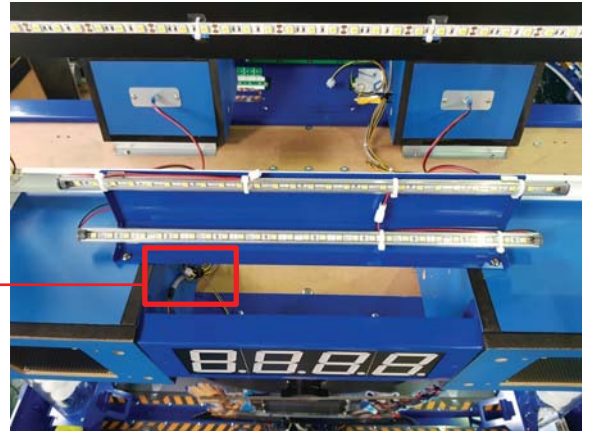
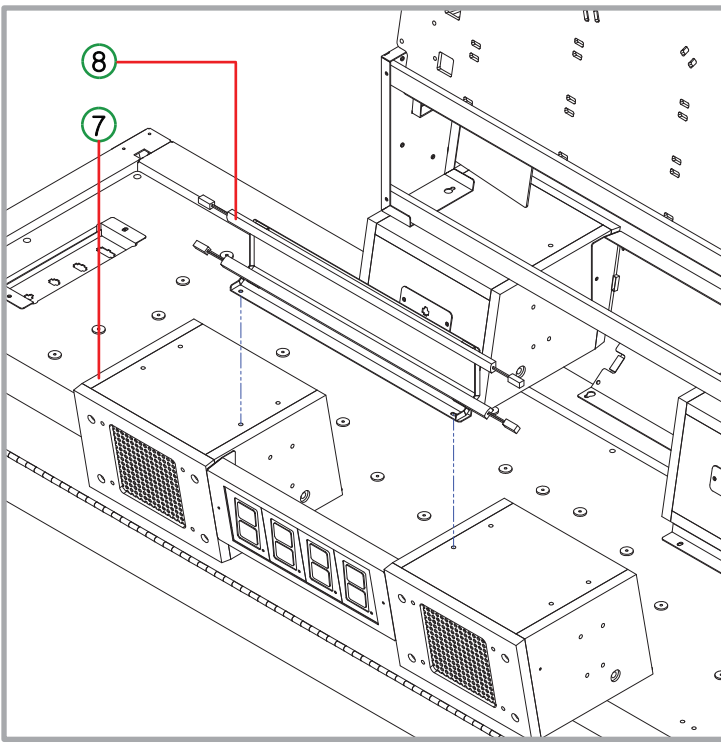

NO	PROCESS	ITEM	Q'TY	BOLT	SPEC	Q'TY
7		BILLBOARD SPEAKER PART				
8	ASSEMBLE	BILLBOARD BIGWIN FND LED PART	1	TH NI	M4*16L	2
9	CONNECTOR	CONNECTION	1			

: The opposite billboard is the same.

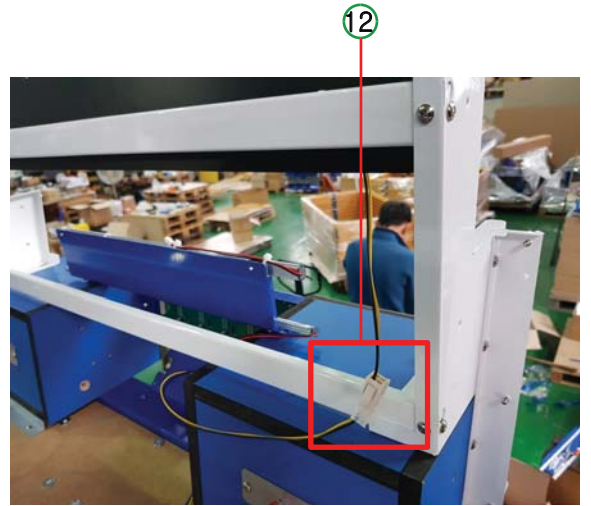
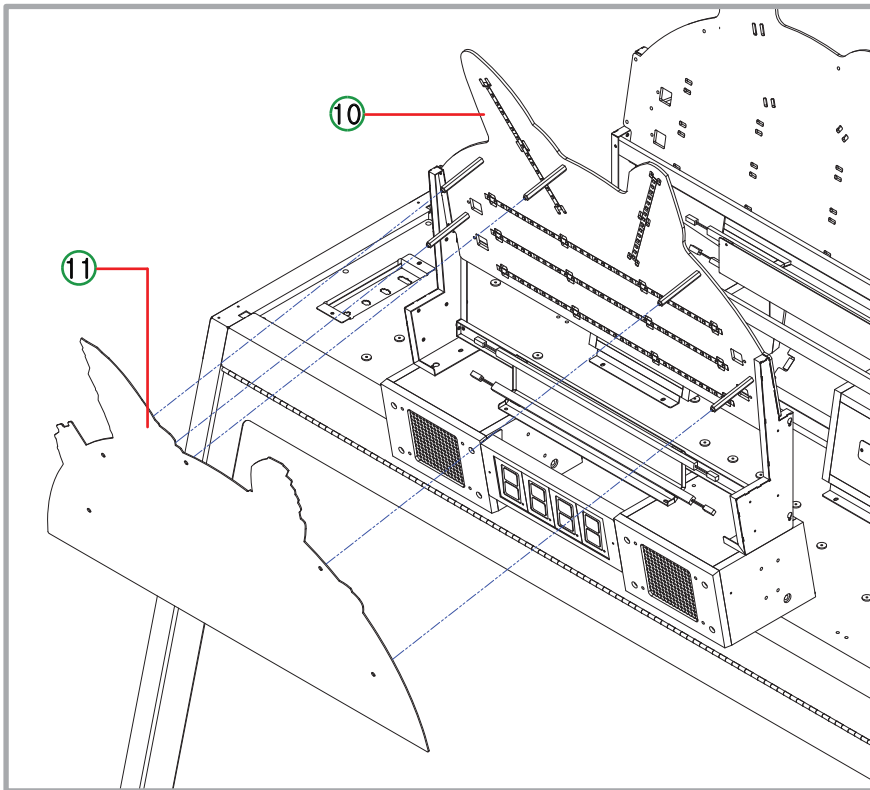

NO	PROCESS	ITEM	Q'TY	BOLT	SPEC	Q'TY
10		BILLBOARD TITLE PART				
11	ASSEMBLE	BILLBOARD TITLE COVER ACRYL	1	TH NI	M4*10L	5
12	CONNECTOR	CONNECTION				

: The opposite billboard is the same.

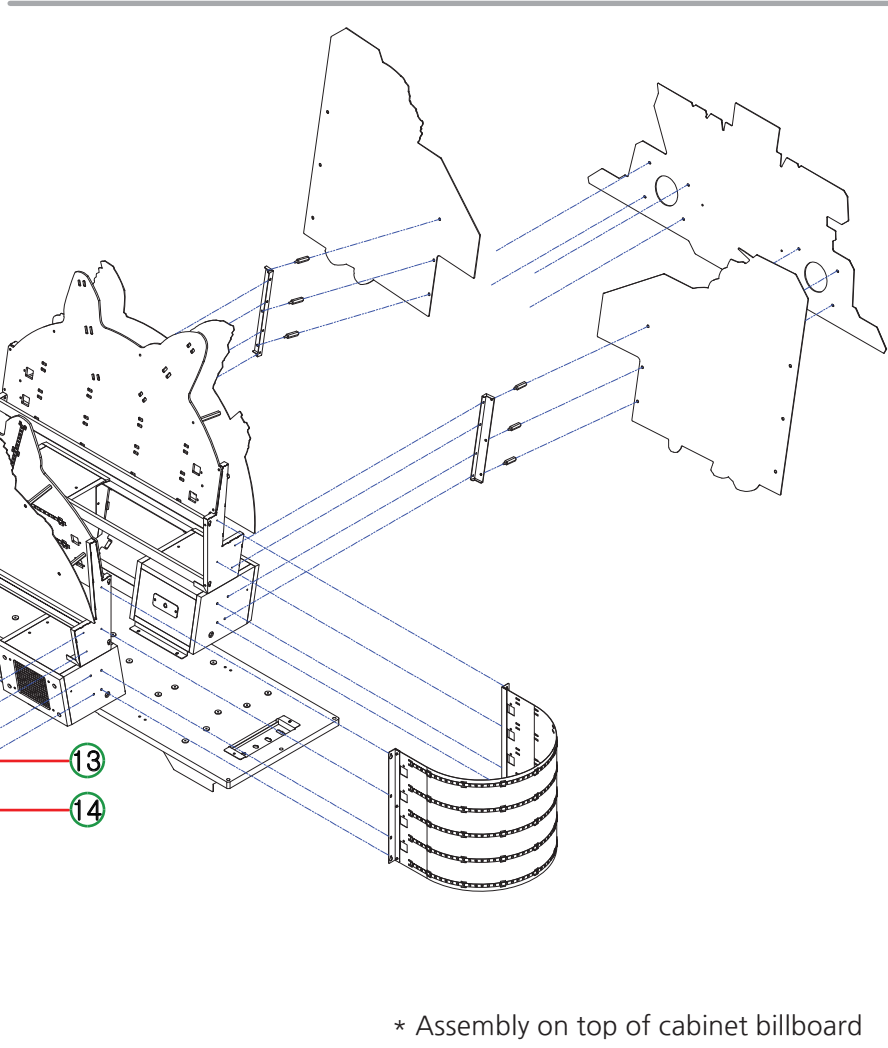
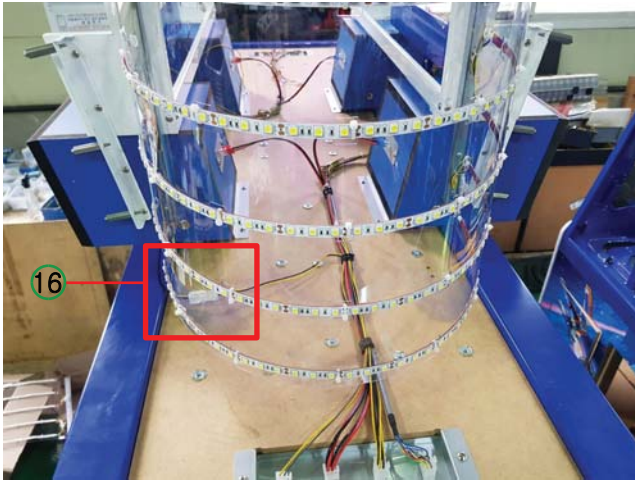

* Assembly on top of cabinet billboard

NO	PROCESS	ITEM	Q'TY	BOLT	SPEC	Q'TY
13		BILLBOARD DECO FIX BKT-R	2	TH NI	M4*6L	8
14	ASSEMBLE	BILLBOARD FRONT ACRYL FIX SHAFT [MGOTOPRO001]	6	TH NI	M4*6L	6
15	ASSEMBLE	BILLBOARD SIDE LIGHT LED PART ASS'Y	2	TH NI	M4*10L	16
16	CONNECTOR	CONNECTION	1			
17	ASSEMBLE	BILLBOARD DECO ACRYL-L	1	TH NI	M4*10L	6
18	ASSEMBLE	BILLBOARD DECO ACRYL-R	1	TH NI	M4*10L	6
19	ASSEMBLE	BILLBOARD BIGWIN FND COVER ACRYL	1	TH NI	M4*10L	10

: The opposite billboard is the same.

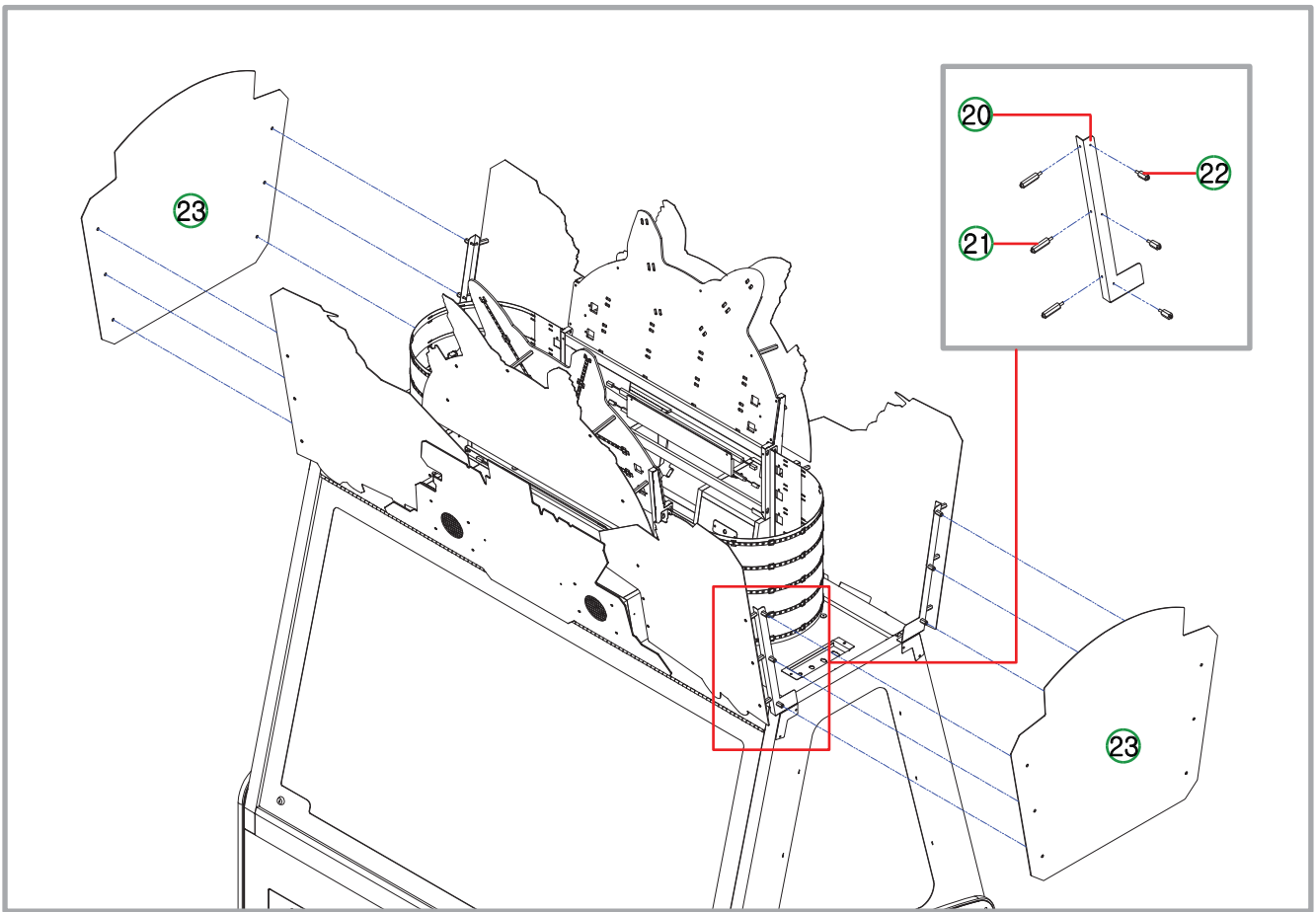

NO	PROCESS	ITEM	Q'TY	BOLT	SPEC	Q'TY
20		BILLBOARD DECO FIX BKT-R	4	TH NI	M4*6L	8
21	ASSEMBLE	BILLBOARD FRONT ACRYL FIX SHAFT [MGOTOPRO001]	12	TH NI	M4*6L	12
22	ASSEMBLE	BILLBOARD SIDE ACRYL FIX SHAFT [MGOTOPRO002]	12	TH NI	M4*10L	12
23	ASSEMBLE	BILLBOARD SIDE POP COVER ACRYL	2	TH NI	M4*10L	12

2) BUTTON ASS'Y

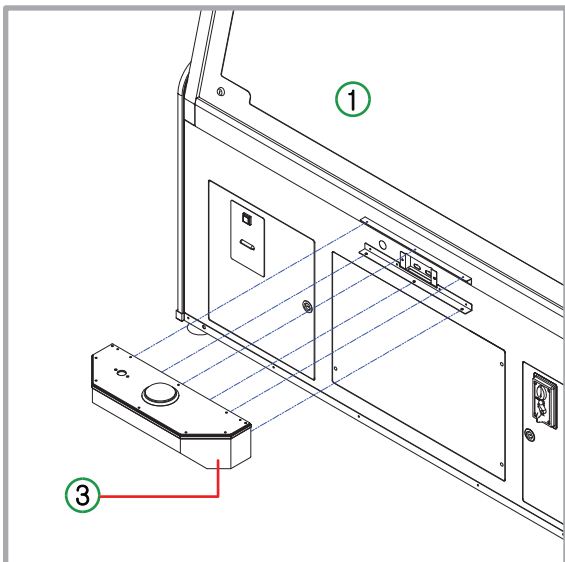

NO	PROCESS	ITEM	Q'TY	BOLT	SPEC	Q'TY
1		CABINET ASS'Y				
2	CONNECTOR	CONNECTION	1			
3	ASSEMBLE	BUTTON ASS'Y	1	TH NI	M4*10L	6

5 SETUP SETTINGS

▶ SETUP BUTTON LAYOUT

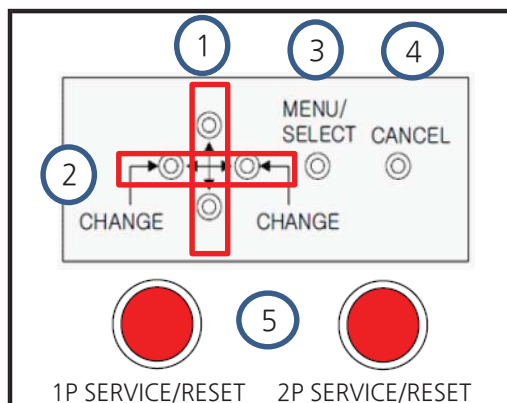

BUTTON	NOTE
1. UP/DOWN	MENU UP/DOWN MOVE
2. LEFT/RIGHT	CHANGE SETTING VALUE
3. MENU/SELECT	SETUP MENU MODE, SELECT AND PERFORM
4. CANCEL	EXIT
5. SERVICE/RESET	Normally service in. In case of error, use this button to clear error. * 1 credit increase by pressing one servic in.

1) OPERATING OPTIONS

PRESS MENU BUTTON. [MENU/SELECT BUTTON: TO ENTER]		
1	PROGRAM SETTINGS	SETUP MODE
2	CLEAR MODE	CLEAR MODE
3	BOOKKEEPING DATA	VIEW GAME DATA
4	FACTORY SETTING	INITIALIZING TO FACTORY SETTING
5	TEST MODE	TEST MODE
6	CALIBRATION MODE	SUNLIGHT SENSOR CALIBRATION MODE
7	EXIT	EXIT TO OPERATION OPTIONS

2) PROGRAM SETTINGS

LCD DISPLAY	DESCRIPTION	RANGE	DEFAULT
CREDIT / COIN	SETTING NUMBER OF CREDIT PER COIN ※ Clear GameData when saving after change	“FREE”, 1/1, 1/2, 1/3, 1/4, 1/5, 2/1, 3/1, 4/1, 5/1, 6/1, 7/1, 8/1, 9/1, 10/1	1/1
PLAYS / BILL	SETTING NUMBER OF PLAYS PER BILL ※ Clear GameData when saving after change	1 ~ 10	1
GAME TIME	SETTING FOR GAME TIME OVER	10 ~ 99 (SECONDS)	30
LIFE TIME	SETTING TRAIN MOVING IN DEMO ON : TRAIN RUNS ALL THE TIME OFF : TRAIN ALWAYS STOPS INT : MEANS INTERVAL. TRAIN WAITS FOR THE SET TIME (AFTER WAITING TIME, DO 3 LAPS AND WAIT AGAIN)	ON , OFF, INT 1MIN, INT 5MIN, INT 10MIN, INT 30MIN, INT 1HRS, INT 3HRS	INT 1MIN
LED COUNT	IF ALL OF THE LAMPS OF TRAIN SCORE BOARD ARE “OFF”, THE LAMPS ARE RANDOMLY “ON” ACCORDING TO THIS SETTING VALUE AT THE BEGINNING (THIS SETTING IS AVAILABLE IN SINGLE MODE OF GAME TYPE ONLY)	0 ~ 5	2
BIGWIN BONUS ※ DIP	SETTING FIRST STARTING VALUE(NUMBER) OF BIGWIN BONUS ※ See Table #2 below	30 ~ 9999 (INCREASES BY 10)	500
BIGWIN LIMIT ※ DIP	SETTING LIMIT VALUE(NUMBER) OF BIGWIN BONUS ※ See Table #2 below	30 ~ 9999 (INCREASES BY 10)	1000
BW-INCREMENT ※ DIP	SETTING INCREASING VALUE(NUMBER) OF BIGWIN BONUS (PER 1 PLAY) ※ See Table #2 below	0 ~ 50 (INCREASES BY 1)	2

TRAIN TYPE	SET TRAIN SPEED NONE : DEFAULT SPEED SLOW : SET SLOW SPEED MIDDLE : SET MIDDLE SPEED FAST : SET FAST SPEED RANDOM : AT EASY OR HARD MODE IN DIFFICULTY, SET RANDOM SPEED (NOT IN NORMAL MODE)	NONE, SLOW, MIDDLE, FAST, RANDOM	MIDDLE
DIFFICULTY	SETTING GAME DIFFICULTY EASY : NO CONTROL OF PROBABILITY NORMAL : CONTROL PROBABILITY OF RED ZONE ONLY HARD : CONTROL PROBABILITY OF RED AND GREEN ZONE	EASY, NORMAL, HARD	EASY
TARGET SCORE ※ DIP	SETTING TICKET SCORE OF EACH CABIN	TABLE BELOW ※ See Table #1 below	

< TABLE #1 >

LCD DISPLAY	DESCRIPTION	RANGE	DEFAULT		
			A Table 3 ref.	B Table 4 ref.	NJ Table 5 ref.
TYPE	REFER TO THE SCORE TABLE BELOW See submenu tables #3 to #5	0 ~ 1 (INCREASED BY 1)	0	0	0
TARGET 1 SCORE	SETTING SCORE 1 CABIN OF TRAIN	0 ~ 200 (INCREASED BY 1)	70	70	70
TARGET 2 SCORE	SETTING SCORE 1 CABIN OF TRAIN	0 ~ 200 (INCREASED BY 1)	30	30	30
TARGET 3 SCORE	SETTING SCORE 1 CABIN OF TRAIN	0 ~ 200 (INCREASED BY 1)	50	50	50
TARGET 4 SCORE	SETTING SCORE 1 CABIN OF TRAIN	0 ~ 200 (INCREASED BY 1)	20	20	20
TARGET 5 SCORE	SETTING SCORE 1 CABIN OF TRAIN	0 ~ 200 (INCREASED BY 1)	100	100	100
TARGET 6 SCORE	SETTING SCORE 1 CABIN OF TRAIN	0 ~ 200 (INCREASED BY 1)	20	20	20
TARGET 7 SCORE	SETTING SCORE 1 CABIN OF TRAIN	0 ~ 200 (INCREASED BY 1)	50	50	50
TARGET 8 SCORE	SETTING SCORE 1 CABIN OF TRAIN	0 ~ 200 (INCREASED BY 1)	30	30	30
TARGET 9 SCORE	SETTING SCORE 1 CABIN OF TRAIN	0 ~ 200 (INCREASED BY 1)	70	70	70
SAVE AND EXIT	SAVE AND EXIT	BY PRESSING SELECT BUTTON, PERFORM BY MOVING THE CURSOR TO [YES] OR [NO]			
CANCEL AND EXIT					

MERCY TICKET ※ DIP	SETTING NUMBER OF TICKETS TO BE DISPENSED IN CASE OF TRY AGAIN	0 ~ 20 (INCREASES BY 1)	2
TICKET/SCORE	SETTING TICKET RATIO PER SCORE NONE : AUTOMATICALLY REDUCING TICKET COUNTS WITHOUT DISPENSING TICKETS	NONE, 1/1, 1/2	1/1
ATTRACT VOLUME	USE OF DEMO SOUND AND SETTING VOLUME OFF : NO SOUND 10 ~ 100 : RATIO OF SOUND VOLUME(%)	OFF, 10 ~ 100 (INCREASED BY 10)	60
SAVE AND EXIT	SAVE AND EXIT	BY PRESSING SELECT BUTTON, PERFORM BY MOVING THE CURSOR TO [YES] or [NO]	
CANCEL AND EXIT	CANCEL AND EXIT		

※ The default value of DIP display items may vary depending on DIP S/W (KSD08H) 2 settings.
For details, refer to the <DIP S/W setting default value> below.

< DIP S/W setting default value >

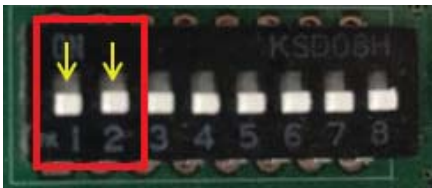

< TABLE #2 >

	A		B		NJ	
DIP 1	ON		OFF		ON	
DIP 2	OFF		OFF		OFF	
SCORE TYPE	기본값		기본값		기본값	
	TYPE	0	TYPE	0	TYPE	0
	AVERAGE	38.5	AVERAGE	38.5	AVERAGE	38.5
	TARGET 1	70	TARGET 1	70	TARGET 1	70
	TARGET 2	30	TARGET 2	30	TARGET 2	30
	TARGET 3	50	TARGET 3	50	TARGET 3	50
	TARGET 4	20	TARGET 4	20	TARGET 4	20
	TARGET 5	100	TARGET 5	100	TARGET 5	100
	TARGET 6	20	TARGET 6	20	TARGET 6	20
	TARGET 7	50	TARGET 7	50	TARGET 7	50
	TARGET 8	30	TARGET 8	30	TARGET 8	30
	TARGET 9	70	TARGET 9	70	TARGET 9	70
MERCY	2	MERCY	2	MERCY	2	
BIGWIN BONUS	500		500		500	
BIGWIN LIMIT	1000		1000		1000	
BW-INCREMENT	2		2		2	

< TABLE #3 >

< SCORE INTERNAL SETTING VALUE FOR EACH TYPE - A >

TYPE	0	1
AVERAGE	38.5	50.8
SUPER BONUS	500	500
SUPER LIMIT	1000	1000
SB-INCREMENT	2	2
TARGET 1	70	80
TARGET 2	30	70
TARGET 3	50	60
TARGET 4	20	40
TARGET 5	100	100
TARGET 6	20	30
TARGET 7	50	70
TARGET 8	30	40
TARGET 9	70	80
MERCY TICKET	2	2

< TABLE #4 >

< SCORE INTERNAL SETTING VALUE FOR EACH TYPE - B >

TYPE	0	1
AVERAGE	38.5	50.8
SUPER BONUS	500	500
SUPER LIMIT	1000	1000
SB-INCREMENT	2	2
TARGET 1	70	80
TARGET 2	30	70
TARGET 3	50	60
TARGET 4	20	40
TARGET 5	100	100
TARGET 6	20	30
TARGET 7	50	70
TARGET 8	30	40
TARGET 9	70	80
MERCY TICKET	2	2

< TABLE #5 >

< SCORE INTERNAL SETTING VALUE FOR EACH TYPE - **NJ** >

TYPE	0	1
AVERAGE	38.5	50.8
BIGWIN BONUS	500	500
BIGWIN LIMIT	1000	1000
BW-INCREMENT	2	2
TARGET 1	70	80
TARGET 2	30	70
TARGET 3	50	60
TARGET 4	20	40
TARGET 5	100	100
TARGET 6	20	30
TARGET 7	50	70
TARGET 8	30	40
TARGET 9	70	80
MERCY TICKET	2	2

★ SCORE TYPE is not initialized even if FACTORY SET is performed and DIP S/W No. 2 setting is changed.
It is initialized only the first time when FACTORY SET.

3) CLEAR MODE : GAME DATA AND BOOKKEEPING CAN BE DELETED

LCD DISPLAY	DESCRIPTION	EXECUTION
CLEAR TICKETS	Delete remaining tickets to be dispensed now	BY PRESSING SELECT BUTTON, PERFORM BY MOVING THE CURSOR TO [YES] or [NO]
CLEAR PLAYS	DELETE REMAINING PLAYS(CREDIT)	
CLEAR DATA	GAME ALL GAME DATA AND BOOKKEEPING DATA INCLUDING CREDITS AND TICKET	
EXIT	Exit	

4) BOOKKEEPING

LCD DISPLAY	DESCRIPTION	LCD DISPLAY	DESCRIPTION
COIN IN 1P : 0 2P : 0 TOTAL : 0	NUMBER OF COIN IN (1P, 2P, TOTAL)	--- TICKET OUT --- 1P : 0 2P : 0 TOTAL : 0	NUMBER OF TICKET OUT (1P, 2P, TOTAL)
--- BILL IN --- 1P : 0 2P : 0 TOTAL : 0	NUMBER OF BILL IN (1P, 2P, TOTAL)	-- BIG WIN -- 1P : 0 2P : 0 TOTAL : 0	NUMBER OF WINNING SUPER BONUS (1P, 2P, TOTAL)
--- SERVICE IN --- 1P : 0 2P : 0 TOTAL : 0	NUMBER OF SERVICE IN AND PLAYS (1P, 2P, TOTAL) (SERVICE BUTTON INCREASES BY 1 PLAYS)	--- TRY AGAIN --- 1P : 0 2P : 0 TOTAL : 0	NUMBER OF TRY AGAIN (1P, 2P, TOTAL)
--- GAME PLAYS --- 1P : 0 2P : 0 TOTAL : 0	NUMBER OF GAME PLAY (1P, 2P, TOTAL)	- TARGET 1(~9) WIN - 1P : 0 2P : 0 TOTAL : 0	NUMBER OF WINNING 1(~9) CABIN (1P, 2P, TOTAL)
--- VER INFO ---	VERSION INFORMATION		
CANCEL BUTTON : EXIT			

5) FACTORY - SETTING : Initialize to factory setting

※ CAUTION : Clear all data and set to default value of game set

6) TEST MODE

TEST ITEMS	SETTING ITEMS	DESCRIPTIONS
INPUT TEST	[=>]	<p>ENTER INTO THE CHECK MODE OF INPUT STATUS EACH SENSOR CAN BE CHECKED BY 1~9 SOUND (BOTH 1P, 2P)</p> <p>#SOUND 1 : BALL SHOOTING MOTOR SENSOR #SOUND 2 : BALL IN SENSOR #SOUND 3 : BALL OUT SENSOR #SOUND 4 : BALL RETURN CHECK SENSOR #SOUND 5 : TRAIN CABIN POSITION CHECK SENSOR #SOUND 6 : TRAIN CABIN BALL CHECK SENSOR #SOUND 7 : BALL RAIL CHECK SENSOR #SOUND 8 : TRAIN SPEED CONTROL START POSITION SENSOR #SOUND 9 : TRAIN SPEED CONTROL END POSITION SENSOR #SOUND 10 : TRAIN MAIN MOTOR ENCODER DIVIDING POINT SENSOR #SOUND 11 : BALL ELEVATOR MOTOR ENCODER DIVIDING POINT SENSOR #SOUND 12 : DOOR SWITCH SENSOR</p>
FND & LAMP		OPERATION TEST FOR LAMP, FND, LED
	OFF	TOTALLY TURN OFF
	STEP	OVERALL ON/OFF FLICKERING
	ON	TOTALLY LIGHT ON
MOT TRAIN	ON/OFF	OVERALL ON/OFF REPETITION
		TRAIN MAIN MOTOR OPERATION TEST RUN BY SELECT BUTTON (ALSO BY GAME BUTTON)
	OFF	STOP TRAIN MAIN MOTOR
	ON	START TRAIN MAIN MOTOR
MOT ELEVATOR		<p>BIGWIN FND [■ ■ ■ ■] : DISPLAY THE TIME TAKEN FOR ONE LAP OF THE TRAIN TICKET FND [■ □ □ □] : DISPLAY COUNTS OF MAIN MOTOR DIVIDING POINT SENSOR (0~F) [□ ■ □ □] : DISPLAY COUNTS OF TRAIN SPEED CONTROL STARTING POINT SENSOR(0~F) [□ □ ■ □] : DISPLAY COUNTS OF TRAIN SPEED CONTROL END SENSOR (0~F) [□ □ □ ■] : DISPLAY COUNTS OF TRAIN CAR CHECK SENSOR (0 ~ F) CREDIT FND [■ ■] : DISPLAY COUNTS OF MAIN MOTOR DIVIDING POINT SENSOR</p>
		BALL ELEVATOR MOTOR OPERATION TEST RUN BY SELECT BUTTON (ALSO BY GAME BUTTON)
	OFF	STOP TRAIN MAIN MOTOR
	ON	START TRAIN MAIN MOTOR
MOT SHOOTER		<p>BIGWIN FND [■ ■ ■ ■] : DISPLAY MOTOR STATUS " On " "OFF "</p> <p>TICKET FND [■ □ □ □] : DISPLAY STATUS OF BALL RETURN SENSOR (0, 1) [□ □ □ ■] : DISPLAY STATUS OF BALL ELEVATOR MOTOR DIVIDING POINT SENSOR (0, 1) CREDIT FND [■ ■] : DISPLAY COUNTS OF BALL ELEVATOR MOTOR DIVIDING POINT SENSOR</p>
		BALL SHOOTER MOTOR OPERATION TEST AFTER SELECTING THE MOTOR BY LEFT, RIGHT BUTTON AND RUN BY SELECT BUTTON (ALSO BY GAME BUTTON)
	ALL	1P, 2P BALL SHOOTER MOTOR ON
	1P	1P BALL SHOOTER MOTOR ON
	2P	2P BALL SHOOTER MOTOR ON

MOT SHOOTER		BIGWIN FND [■□□□] : DISPLAY STATUS OF BALL SHOOTER MOTOR SENSOR (0, 1) [□■□□] : DISPLAY STATUS OF BALL IN SENSOR (0, 1) [□□■□] : DISPLAY STATUS OF BALL OUT SENSOR (0, 1) [□□□■] : DISPLAY STATUS OF BALL RAIL SENSOR (0, 1) CREDIT FND [■■] : DISPLAY CHECK COUNTS OF BALL SHOOTER MOTOR SENSOR
COIN		COIN MACHINE TEST BY SELECT BUTTON BOTH OF 1P, 2P ON AND OFF BY 1P, 2P GAME BUTTON ON AND OFF SEPARATELY
	ON, OFF	COIN MACHINE ON, OFF
		BIGWIN FND [■□□□] : DISPLAY STATUS OF POWER OF COIN SENSOR (0 or 1) [□□□■] : DISPLAY STATUS OF COIN SENSOR (0 or 1) CREDIT FND [■■] : DISPLAY CHECK COUNTS OF COIN SENSOR (REPEATLY COUNTING 00 ~ 99)
BILL		BILL MACHINE TEST BY SELECT BUTTON BOTH OF 1P, 2P ON AND OFF BY 1P, 2P GAME BUTTON ON AND OFF SEPARATELY
	ON, OFF	BILL ACCEPTOR ON, OFF
		BIGWIN FND [■□□□] : DISPLAY STATUS OF POWER OF BILL ACCEPTOR (0 or 1) [□□□■] : DISPLAY STATUS OF BILL ACCEPTOR SENSOR (0 or 1) CREDIT FND [■■] : DISPLAY CHECK COUNTS OF BILL ACCEPTOR SENSOR (REPEATLY COUNTING 00 ~ 99)
TICKET		TICKET MACHINE TEST AFTER SELECTING TICKET MACHINES BY LEFT, RIGHT BUTTON AND TEST BY SELECT BUTTON. BY 1P, 2P SERVICE AND GAME BUTTON ON AND OFF SEPARATELY (3 TICKETS DISPENSING)
	ALL	TEST ALL TICKET MACHINES (3 TICKETS DISPENSING)
	1P, 2P	TEST 1P AND 2P TICKET MACHINES(3TICKETS DISPENSING)
		BIGWIN FND [□□□■] : DISPLAY COUNTS OF DISPENSED TICKETS CREDIT FND [■□] : DISPLAY STATUS OF BUTTON OF TICKET MACHINE (0, 1) [□■] : DISPLAY STATUS OF SENSOR OF TICKET MACHINE (0, 1)
COUNTER		COUNTER MACHINE TEST AFTER SELECTING COUNTER MACHINES BY LEFT, RIGHT BUTTON AND 1 COUNT UP BY SELECT BUTTON
	“COIN”, “TICKET”	TEST ALL TICKET COUNTERS 1 COUNT UP EACH IN ORDER OF 1P ► 2P
SOUND TEST		SOUND TEST AFTER SELECTING SPEAKERS BY LEFT, RIGHT BUTTON AND TEST BY SELECT BUTTON (PLAY, STOP)
	CH	PLAY VOICE One ~ Eight BY EACH SPEAKER CHANNEL 1P LEFT : 1, 5 / 1P RIGHT : 2, 6 / 2P LEFT : 3, 7 / 2P RIGHT : 4, 8
	BGM	BGM SOUND TEST
	SFX	SFX SOUND TEST
	VOC	VOC SOUND TEST
EXIT		EXIT TO OPERATING OPTIONS

- Before CALIBRATION TEST, go to GAME MODE and rotate the train once in demo state.

7) CALIBRATION MODE

TEST ITEMS	SETTING ITEMS	DESCRIPTIONS
TRAIN CAR		SUNLIGHT SENSOR CALIBRATION TEST ◎ USE THE LEFT AND RIGHT BUTTONS TO SELECT THE TRAIN CAR LOCATION AND PRESS THE SELECT BUTTON, THE TRAIN MOVES AND STOPS AT THE CORRESPONDING SPACE POSITION ◎ PRESS THE SELECT BUTTON TO STOP AT THE NEXT TRAIN CAR (1P, 2P game buttons work the same as SELECT buttons)
	"1 ~ 9"	STOP AT SELECTED TRAIN CAR LOCATION
		BIGWIN FND [■ ■ ■ ■] : BALL DETECTION SENSOR DETECTION TIME DISPLAY CREDIT FND [■ ■] : TRAIN CAR SENSOR CHECK COUNT DISPLAY (REPEAT 0 TO 9 COUNTS) CHECKER LED [■ □] : "SUCC" LED IS ON WHEN BALL IS DETECTED, OFF WHEN NO BALL IS DETECTED [□ ■] : "FAIL" LED IS ON WHEN THE TRAIN CAR SEQUENCE CHECK SENSOR DETECTS STEEL PLATE, OFF WHEN NO IRON PLATE IS DETECTED * Please refer to the attached document for the method of CALIBRATION of the sunlight sensor
TRAIN TEST		SUNLIGHT SENSOR CALIBRATION TEST ◎ WHEN THE SELECT BUTTON IS PRESSED, THE TRAIN MOTOR TURNS ON AND OFF ◎ 1P, 2P GAME BUTTONS TO TURN THE TRAIN MOTOR ON AND OFF
	"ON", "OFF"	
		BIGWIN FND [■ ■ ■ ■] : BALL DETECTION SENSOR DETECTION TIME DISPLAY CREDIT FND [■ ■] : TRAIN CAR SENSOR CHECK COUNT DISPLAY (REPEAT 0 TO 9 COUNTS) CHECKER LED [■ □] : "SUCC" LED IS ON WHEN BALL IS DETECTED, OFF WHEN NO BALL IS DETECTED [□ ■] : "FAIL" LED IS ON WHEN THE TRAIN CAR SEQUENCE CHECK SENSOR DETECTS STEEL PLATE, OFF WHEN NO IRON PLATE IS DETECTED * Please refer to the attached document for the method of CALIBRATION of the sunlight sensor

[SENSOR CALIBRATION MANUAL]

(How to proceed in the product state)

1. Turn off the power to the product and proceed. (location on the train does not matter)
2. Remove the SENSOR COVER BRACKET. (3 SCREW)

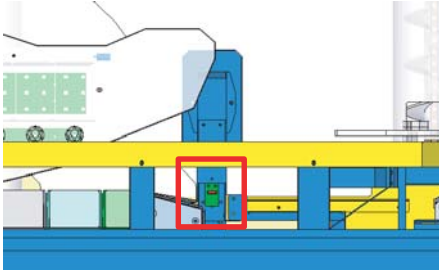

3. Remove Loctite applied to variable resistor.

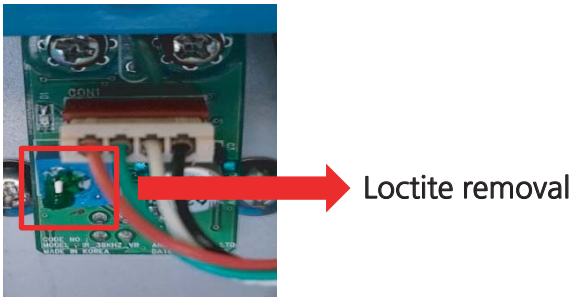

4. Turn on the product.
5. Immediately after pressing the SELECT button on the SETUP PANEL, use the DOWN button to enter CALIBRATION MODE.
6. After changing OFF1 to OFF2 by pressing the RIGHT button in TRAIN CAR
Press the SELECT button to turn it on.
7. When the train stops in car 2, place the ball in the center of the sensor hole and align it with the outer edge of the train car.
(Please check the location by referring to the photo data below)

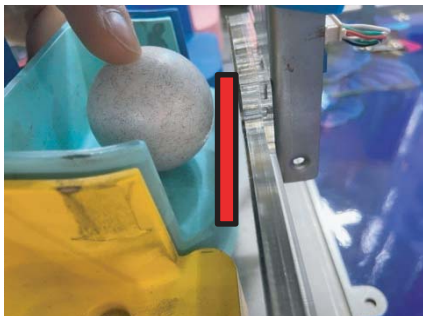

8. Insert the variable resistor in the center using a "+" driver.

- 1) Rotate the driver to the point where the red LED located on the back of the sensor PCB turns on.
- 2) When the LED is ON, stop the driver rotation, move the ball about 5mm back, and check if the red LED is OFF.
- 3) If the red LED does not turn off, rotate the variable resistor from that state to the point where it turns off using the + driver.
- 4) When the red LED is OFF, check if the red LED is ON by matching it with the outside of the train car again.
- 5) When the red LED turns on, move 5mm again and check if the red LED turns off.
- 6) If the red LED is OFF in item 5), proceed to the final test. If it is ON instead of OFF, repeat items 3) to 5) until it is completed.

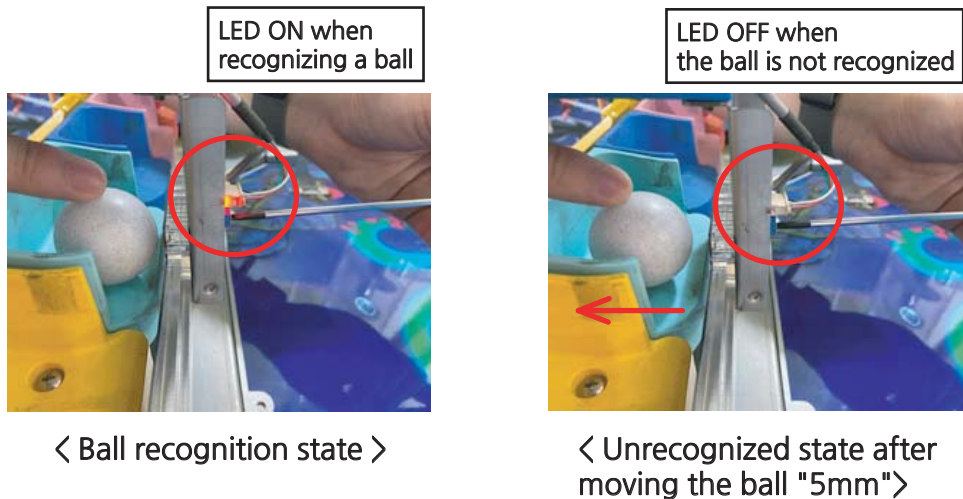

9. final test

- 1) After calibration is complete, press CANCEL twice to enter GAME MODE.
- 2) CALIBRATION Enter the SERVICE button of the PLAYZONE to proceed with the game, press the GAME BUTTON to launch the ball into the train car, and check the success/absence of success.
(No problem if the color of the train car with the ball matches the LED output for score distribution)
- 3) If there is no problem, apply Loctite to the variable resistor and fasten the sensor cover BKT.
- 4) If the ball is not recognized or the ball is recognized in a train car without a ball, refer to the above 6th paragraph and proceed with the CALIBRATION again.

8) ERROR CODE

ERROR CODE	ERROR TYPE	CONTENS	CHECK POINTS
Er.02	SYSTEM	Setup save data problem	1. Check and save setup settings 2. FACTORY SET 3. Check power ON and OFF 4. If the problem persists, replace the motherboard
Er.03		Game save data problem	1. CLEAR DATA in SETUP CLEAR MODE 2. Check power ON and OFF 3. If the problem persists, replace the motherboard
Er.11	COIN MACHINE	Player Coin Sensor Signal Still Present	Players having problems Coin machine sensor input check
Er.13	BILL ACCEPTOR	Player Bill Recognizer Sensor Signal Still Present	Players having problems Bill Recognition Sensor Input Check
Er.21	VIDEO BOARD COMMUNICATION ERROR	Main board and video IO board communication problem	1. Check communication wiring 2. Check communication status 3. Check the video board and main board
Er.22	VIDEO BOARD VERSION ERROR	If the version of the main board and the video IO board are different problem occurred	1. Check the main board and video board version
Er.31	MAIN(TRAIN) MOTOR	Encoder branch signal is absent or is still present	1. Check motor operation status 2. Encoder sensor input status check
Er.32	MAIN(TRAIN) SEQUENCE CHECK SENSOR	Train sequence check sensor signal (When there is no signal, or when there is still)	1. Check sensor input status
Er.33	TRAIN SPEED CONTROL START SENSOR	Train speed control start sensor signal problem (When there is no signal, or when there is still)	1. Check sensor input status
Er.34	TRAIN SPEED CONTROL END SENSOR	Train speed control end sensor signal problem	1. Check sensor input status
Er.35	MAIN (TRAIN) ORDER CONFIRMATION SENSOR	Train sequence check sensor signal problem (When the train order signal comes in with a strange value)	1. Check sensor input status 2. Check the condition of the hardware in the train compartment
Er.41	BALL ELEVATOR MOTOR	Encoder branch signal problem	1. Check motor operation status 2. Encoder sensor input status check
Er.42	BALL RETURN SENSOR	Elevator entry sensor problem	1. Check sensor input status
Er.51	BALL SHOOTER SENSOR	No sensor signal after ball launch	1. Check the ball firing (shooter) operation status 2. Check sensor input status
Er.61	BALL IN SENSOR	Signal problem with ball IN sensor (Still no signal)	1. Check sensor input status
Er.62	BALL OUT SENSOR	Ball OUT sensor signal problem (When there is no signal, or when there is still)	1. Check sensor input status
Er.63	BALL RAIL SENSOR	Ball rail sensor signal problem (When there is no signal, or when there is still)	1. Check sensor input status

Er.64	BALL SUCCESS SENSOR	Ball success sensor signal problem (When there is no signal, or when there is still)	1. Check sensor input status
Er.80	BALL SUCCESS SENSOR CHEATING ERROR	The ball detection signal is higher than the number of balls fired. occurs in many cases	1. Check sensor input status
HELP	TICKET	No ticket	1. Ticket check 2. Check ticket motor operation 3. Check Ticket discharge Sensor
※ The error code is displayed on the BIGWIN FND of the player where the error occurred. (For the error code display of test mode, refer to the description of TESTMODE)			

6 MAINTENANCE

- 1) Precautions for turning on the power.
: When it is newly turned on after power is turned off, the power must be turned on after 10 seconds.
- 2) When installing the device
: Connect the device with a ground outlet to which fg is connected.
- 3) Main board management.
: Dust removal on the main board will be carried out once a month.
- 4) Basic product management: Clean it regularly
- 5) This product should only be used for indoor use

7 SOLUTION

1) ERROR CODE

CODE	ERROR	NOTE
E.02	SYSTEM	Setup save data problem
E.03	SYSTEM	Setup save data problem
E.11	COIN MACHINE	Player Coin Sensor Signal Still Present
E.13	BILL ACCEPTOR	Player Bill Recognizer Sensor Signal Still Present
E.21	VIDEO BOARD COMMUNICATION ERROR	Main board and video IO board communication problem
E.22	VIDEO BOARD VERSION ERROR	The main board and video board version
E.31	MAIN(TRAIN) MOTOR	Encoder branch signal is absent or is still present
E.32	MAIN(TRAIN) SEQUENCE CHECK SENSOR	Train sequence check sensor signal problem
E.33	TRAIN SPEED CONTROL START SENSOR	Train speed control start sensor signal problem
E.34	TRAIN SPEED CONTROL END SENSOR	Train speed control end sensor signal problem
E.35	MAIN(TRAIN) SEQUENCE CHECK SENSOR	Train sequence check sensor signal problem
E.41	BALL ELEVATOR MOTOR	Encoder branch signal problem
E.42	BALL RETURN SENSOR	Elevator entry sensor problem
E.51	BALL SHOOTER SENSOR	No sensor signal after ball launch
E.61	BALL IN SENSOR	Signal problem with ball IN sensor
E.62	BALL OUT SENSOR	Ball OUT sensor signal problem
E.63	BALL RAIL SENSOR	Ball rail sensor signal problem
E.64	BALL SUCCESS SENSOR	Ball success sensor signal problem
E.80	BALL SUCCESS SENSOR CHEATING ERROR	The ball detection signal is higher than the number of balls fired
HELP	TICKET ERROR	NO TICKET OR DISPENSING

※ NORMALLY ERROR CODE WILL BE DISPLAYED AT PLAYER'S BIGWIN FND

VIEW FRONT		VIEW UPPER	
	Er.61		Er.61 Er.62
	Er.62		Er.33
	Er.51	Er.64 Er.80	
	Er.34	Er.42	
	Er.35	Er.63	
	Er.32		
	Er.31		
	Er.41		
	Er.11		
	HELP		
	Er.02		
	Er.03		
	Er.21	Er.13	

1) SYSTEM ERROR (Er.02, Er.03)

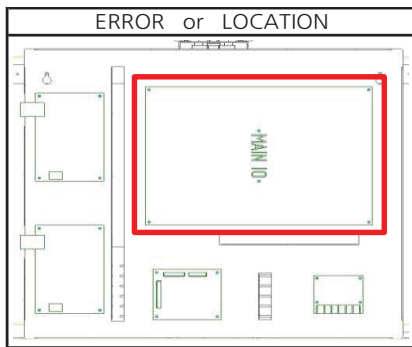

► SOLUTION			
1. CHECK :			
1) Recheck after power off/on			
2) Recheck after factory set			
3) MAIN PCB replacement			
PART NAME		CODE	
MAIN I/O PCB ASS'Y		AGOT0ASS001	

2) COIN MACHINE ERROR (Er.11)

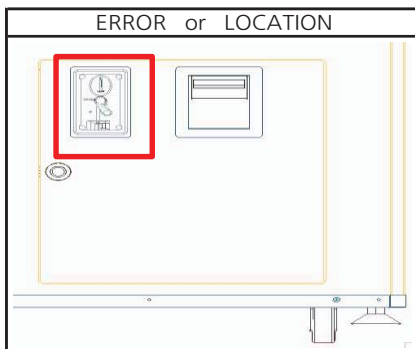

► SOLUTION			
1. TEST MODE → COIN TEST			
2. CHECK :			
1) Check whether COIN JAM			
2) Check the cable connection status			
3) REPLACE COIN MACHINE			
4) MAIN PCB replacement			
PART NAME		CODE	
COIN SELECTOR		MZZZ0COS052	MAIN I/O PCB ASS'Y
		AGOT0ASS001	

3) BILL ACCEPTOR ERROR (Er.13)

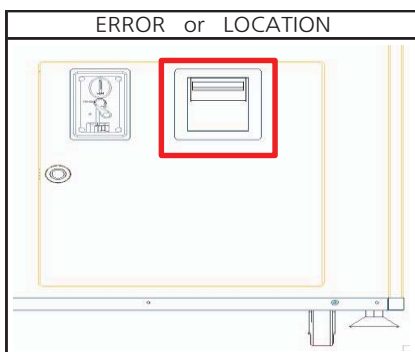

► SOLUTION			
1. TEST MODE → BILL TEST			
2. CHECK :			
1) Check whether BILL JAM			
2) Check the cable connection status			
3) REPLACE BILL ACCEPTOR			
4) MAIN PCB replacement			
PART NAME		CODE	
MAIN I/O PCB ASS'Y		AGOT0ASS001	

4) VIDEO COMMUNICATION ERROR (Er.21)

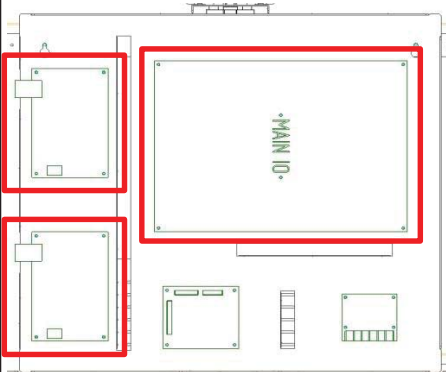
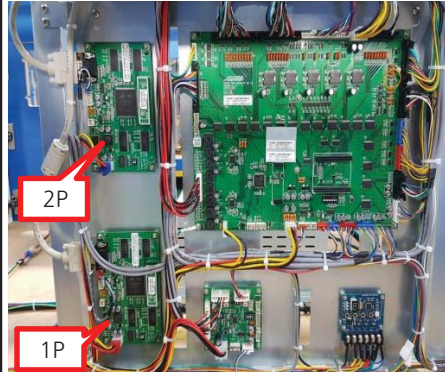
ERROR or LOCATION	P1	P2
		

► SOLUTION			
1. TEST MODE → FND & LAMP TEST ► STEP : Operates in the order of RED → GREEN → BLUE → WHITE *On the monitor screen 2. CHECK : 1) Check whether the monitor is working : Remove the RGB cable from the monitor to check whether NO SIGNAL DISPLAY is displayed on the monitor.		2) Replace the monitor when NO SIGNAL is not output 3) VIDEO, MAIN PCB assembly check 4) Check wiring connections 5) VIDEO PCB replacement (1P: down, 2P: up) 6) MAIN PCB Replacement	
PART NAME	CODE	PART NAME	CODE
VIDEO PCB ASS'Y_EAGLE	AGOT0PCB005	MAIN I/O PCB ASS'Y	AGOT0ASS001

5) MAIN(TRAIN) MOTOR & SENSOR ERROR (Er.31)

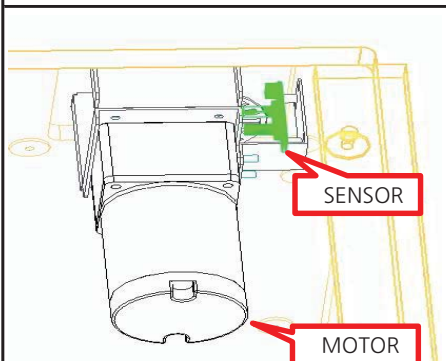
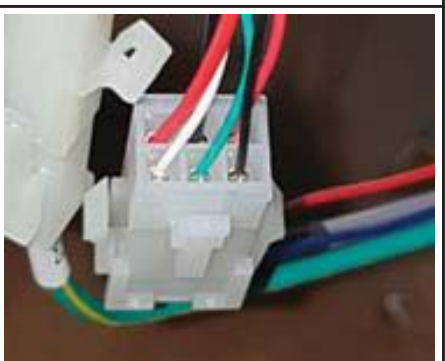
ERROR or LOCATION	P1	P2																												
		<table border="1"> <tr> <td>3</td> <td>2</td> <td>1</td> <td></td> </tr> <tr> <td>6</td> <td>5</td> <td>4</td> <td></td> </tr> </table> <table border="1"> <tr> <td>1</td> <td>-8V or more</td> <td></td> </tr> <tr> <td>2</td> <td>GND</td> <td></td> </tr> <tr> <td>3</td> <td>4.5V or more</td> <td></td> </tr> <tr> <td>4</td> <td>0.1V or less</td> <td></td> </tr> <tr> <td rowspan="2">5</td> <td>0.1V or less</td> <td>detect</td> </tr> <tr> <td>4.5V or more</td> <td>undetected</td> </tr> <tr> <td>6</td> <td>GND</td> <td></td> </tr> </table>	3	2	1		6	5	4		1	-8V or more		2	GND		3	4.5V or more		4	0.1V or less		5	0.1V or less	detect	4.5V or more	undetected	6	GND	
3	2	1																												
6	5	4																												
1	-8V or more																													
2	GND																													
3	4.5V or more																													
4	0.1V or less																													
5	0.1V or less	detect																												
	4.5V or more	undetected																												
6	GND																													

► SOLUTION			
1. TEST MODE → MOT TRAIN TEST ► TICKET FND : First digit change confirmation ► CREDIT FND : branch sensor display 2. CHECK : 1) Check the assembly status of couplings and other motor connection devices 2) Check the cable connection (P1)		3) Check chain and fixture deformation 4) Motor voltage measurement (P2) 5) MOTOR replacement 6) Sensor PCB voltage measurement (P2) 7) SENSOR PCB replacement 8) MAIN PCB replacement	
PART NAME	CODE	PART NAME	CODE
GEAR HEAD	MZZM0MOT019	MOTOR	MZZM0MOT016
PHOTO INT-1 PCB ASS'Y	AZZZ0PCB103	MAIN I/O PCB ASS'Y	AGOT0ASS001

6) MAIN(TRAIN) SEQUENCE CHECK SENSOR ERROR (Er.32)

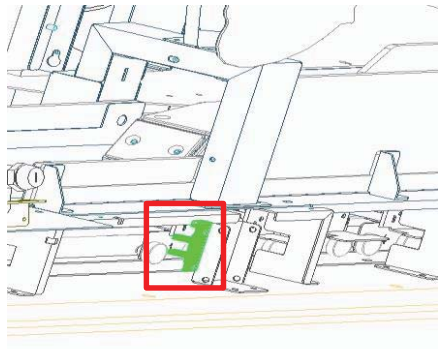
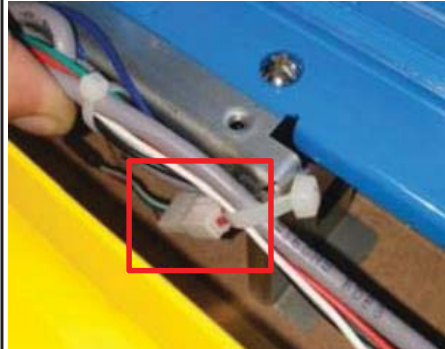
ERROR or LOCATION	P1	P2									
		<table border="1"> <tr><td>1</td><td></td></tr> <tr><td>2</td><td></td></tr> <tr><td>3</td><td></td></tr> <tr><td>4</td><td></td></tr> </table>	1		2		3		4		
1											
2											
3											
4											
		1	4.5V or more								
		2	0.1V or less								
		3	4.5V or more	detect							
			0.1V or less	undetected							
		4	GND								

► SOLUTION			
<p>1. TEST MODE → MOT TRAIN TEST ► TICKET FND : 4th digit change confirmation</p> <p>2. CHECK : 1) Check the assembly status of chain and train injection moldings 2) Check the cable connection (P1)</p>		<p>3) Check Part Deformation (P1) 4) Sensor PCB voltage measurement (P2) 5) SENSOR PCB replacement 6) MAIN PCB replacement</p>	
PART NAME	CODE	PART NAME	CODE
PHOTO INT-1 PCB ASS'Y	AZZZ0PCB103	MAIN I/O PCB ASS'Y	AGOT0ASS001

7) TRAIN SPEED CONTROL START SENSOR ERROR (Er.33)

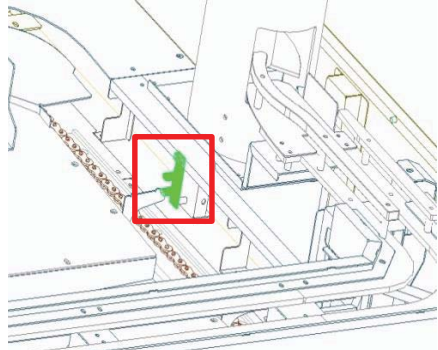
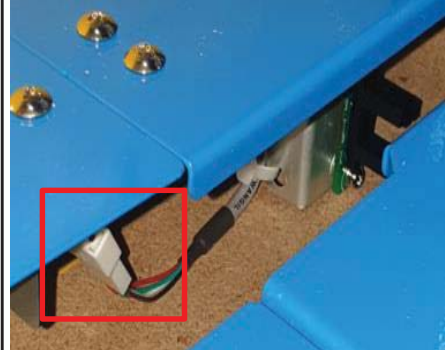
ERROR or LOCATION	P1	P2									
		<table border="1"> <tr><td>1</td><td></td></tr> <tr><td>2</td><td></td></tr> <tr><td>3</td><td></td></tr> <tr><td>4</td><td></td></tr> </table>	1		2		3		4		
1											
2											
3											
4											
		1	4.5V or more								
		2	0.1V or less								
		3	4.5V or more	detect							
			0.1V or less	undetected							
		4	GND								

► SOLUTION			
<p>1. TEST MODE → MOT TRAIN TEST ► TICKET FND : Check the second digit change</p> <p>2. CHECK : 1) Check the assembly status of chain and train injection moldings 2) Check the cable connection (P1)</p>		<p>3) Check Part Deformation (P1) 4) Sensor PCB voltage measurement (P2) 5) SENSOR PCB replacement 6) MAIN PCB replacement</p>	
PART NAME	CODE	PART NAME	CODE
PHOTO INT-1 PCB ASS'Y	AZZZ0PCB103	MAIN I/O PCB ASS'Y	AGOT0ASS001

8) TRAIN SPEED CONTROL END SENSOR ERROR (Er.34)

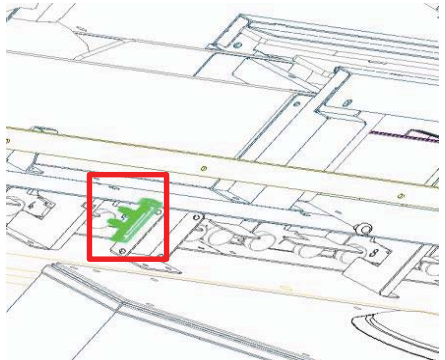
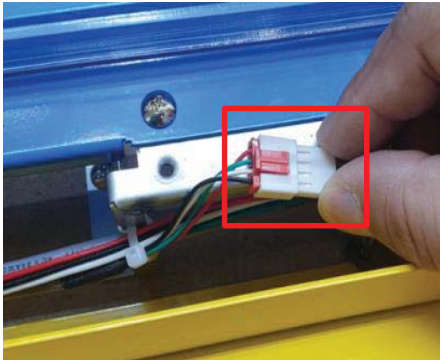
ERROR or LOCATION	P1	P2									
		<table border="1"> <tr><td>1</td><td></td></tr> <tr><td>2</td><td></td></tr> <tr><td>3</td><td></td></tr> <tr><td>4</td><td></td></tr> </table>	1		2		3		4		
1											
2											
3											
4											
		1	4.5V or more								
		2	0.1V or less								
		3	4.5V or more	detect							
			0.1V or less	undetected							
		4	GND								

▶ SOLUTION			
<p>1. TEST MODE → MOT TRAIN TEST ▶ TICKET FND : 3rd digit change confirmation</p> <p>2. CHECK : 1) Check the assembly status of chain and train injection moldings 2) Check the cable connection (P1)</p>		<p>3) Check Part Deformation (P1) 4) Sensor PCB voltage measurement (P2) 5) SENSOR PCB replacement 6) MAIN PCB replacement</p>	
PART NAME	CODE	PART NAME	CODE
PHOTO INT-1 PCB ASS'Y	AZZZ0PCB103	MAIN I/O PCB ASS'Y	AGOT0ASS001

9) MAIN(TRAIN) SEQUENCE CHECK SENSOR ERROR (Er.35)

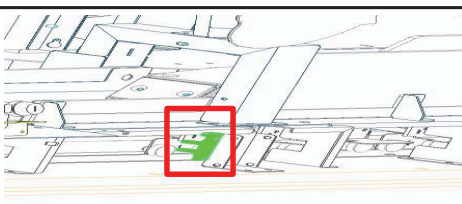
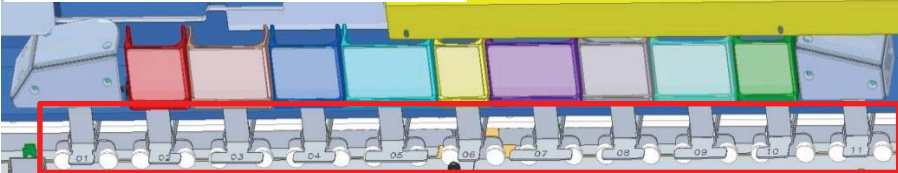
ERROR or LOCATION (P1)	P2									
 	<table border="1"> <tr><td>1</td><td></td></tr> <tr><td>2</td><td></td></tr> <tr><td>3</td><td></td></tr> <tr><td>4</td><td></td></tr> </table>	1		2		3		4		
1										
2										
3										
4										
	1	4.5V or more								
	2	0.1V or less								
	3	4.5V or more	detect							
		0.1V or less	undetected							
	4	GND								

▶ SOLUTION			
<p>1. TEST MODE → MOT TRAIN TEST ▶ TICKET FND : 4th digit change confirmation</p> <p>2. CHECK : 1) Check the train assembly status and check the order of the bottom part (01 ~ 11 / P1) 2) Confirmation of lower BKT deformation and assembly status (P1)</p>		<p>3) Check wiring connections (P2) 4) Sensor PCB voltage measurement (P2) 5) SENSOR PCB replacement 6) MAIN PCB replacement</p>	
PART NAME	CODE	PART NAME	CODE
PHOTO INT-1 PCB ASS'Y	AZZZ0PCB103	MAIN I/O PCB ASS'Y	AGOT0ASS001

10) BALL ELEVATOR MOTOR & SENSOR ERROR (Er.41)

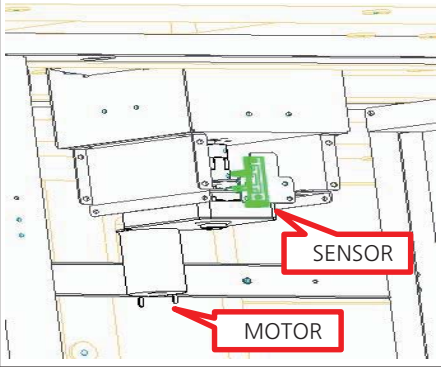
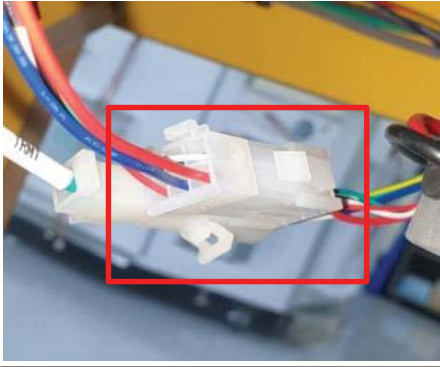
ERROR or LOCATION	P1	P2																										
		<table border="1"> <tr> <td>4</td> <td>5</td> <td>6</td> </tr> <tr> <td>1</td> <td>2</td> <td>3</td> </tr> <tr> <td>1</td> <td>11V or more</td> <td></td> </tr> <tr> <td>2</td> <td>GND</td> <td></td> </tr> <tr> <td>3</td> <td>4.5V or more</td> <td></td> </tr> <tr> <td>4</td> <td>0.1V or less</td> <td></td> </tr> <tr> <td rowspan="2">5</td> <td>0.1V or less</td> <td>detect</td> </tr> <tr> <td>4.5V or more</td> <td>undetected</td> </tr> <tr> <td>6</td> <td>GND</td> <td></td> </tr> </table>	4	5	6	1	2	3	1	11V or more		2	GND		3	4.5V or more		4	0.1V or less		5	0.1V or less	detect	4.5V or more	undetected	6	GND	
4	5	6																										
1	2	3																										
1	11V or more																											
2	GND																											
3	4.5V or more																											
4	0.1V or less																											
5	0.1V or less	detect																										
	4.5V or more	undetected																										
6	GND																											

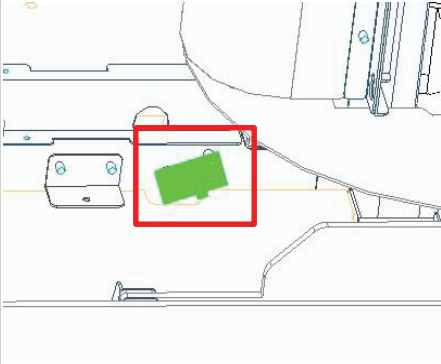
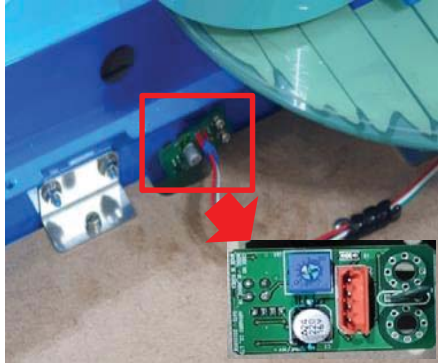

► SOLUTION			
<p>1. TEST MODE → MOT ELEVATOR TEST</p> <ul style="list-style-type: none"> ▶ BIGWIN FND : Check "ON" display ▶ TICKET FND : 4th digit change confirmation ▶ CREDIT FND : branch sensor display <p>2. CHECK :</p> <p>1) Check the assembly status of couplings and other motor connection devices</p>		<p>2) Check the cable connection (P1)</p> <p>3) Check chain and fixture deformation</p> <p>4) Motor voltage measurement (P2)</p> <p>5) MOTOR replacement</p> <p>6) Sensor PCB voltage measurement (P2)</p> <p>7) SENSOR PCB replacement</p> <p>8) MAIN PCB replacement</p>	
PART NAME	CODE	PART NAME	CODE
MOTOR	MZZM0MOT008	PHOTO INT-1 PCB ASS'Y	AZZZ0PCB103
MAIN I/O PCB ASS'Y	AGOT0ASS001		

11) BALL RETURN SENSOR ERROR (Er.42)

ERROR or LOCATION	P1	P2																										
		<table border="1"> <tr> <td>1</td> <td></td> <td></td> </tr> <tr> <td>2</td> <td></td> <td></td> </tr> <tr> <td>3</td> <td></td> <td></td> </tr> <tr> <td>4</td> <td></td> <td></td> </tr> <tr> <td>1</td> <td>4.5V or more</td> <td></td> </tr> <tr> <td>2</td> <td>0.1V or less</td> <td></td> </tr> <tr> <td rowspan="2">3</td> <td>0.1V or less</td> <td>detect</td> </tr> <tr> <td>4.5V or more</td> <td>undetected</td> </tr> <tr> <td>4</td> <td>GND</td> <td></td> </tr> </table>	1			2			3			4			1	4.5V or more		2	0.1V or less		3	0.1V or less	detect	4.5V or more	undetected	4	GND	
1																												
2																												
3																												
4																												
1	4.5V or more																											
2	0.1V or less																											
3	0.1V or less	detect																										
	4.5V or more	undetected																										
4	GND																											

► SOLUTION			
<p>1. TEST MODE → INPUT TEST</p> <ul style="list-style-type: none"> ▶ Output sound upon sensor recognition: 4 <p>2. CHECK :</p> <p>1) Check for ball jams & balls</p> <p>2) Check the cable connection (P1)</p>		<p>3) Check Part Deformation (P1)</p> <p>4) Sensor PCB voltage measurement (P2)</p> <p>5) Proceed through the calibration mode specified in the manual in order</p> <p>6) SENSOR PCB replacement</p> <p>7) MAIN PCB replacement</p>	
PART NAME	CODE	PART NAME	CODE
38KHZ IR SENSOR PCB VR ASS'Y_2CM	ASBT0PCB008	MAIN I/O PCB ASS'Y	AGOT0ASS001

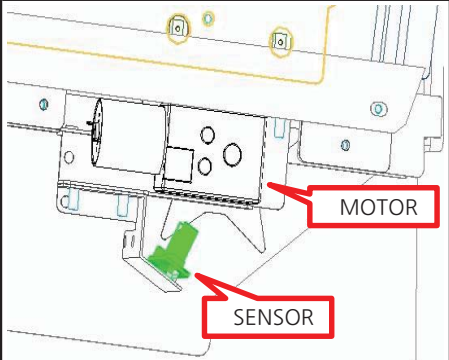
12) BALL SHOOTER MOTOR & SENSOR ERROR (Er.51)

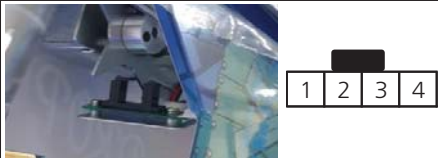
ERROR or LOCATION	P1	P2																			
	 <table border="1"> <tr> <td>1</td> <td>-9V or more</td> </tr> <tr> <td>2</td> <td>GND</td> </tr> </table>	1	-9V or more	2	GND	 <table border="1"> <tr> <td>1</td> <td>4.5V or more</td> <td></td> </tr> <tr> <td>2</td> <td>0.1V or less</td> <td></td> </tr> <tr> <td>3</td> <td>4.5V or more</td> <td>detect</td> </tr> <tr> <td></td> <td>0.1V or less</td> <td>undetected</td> </tr> <tr> <td>4</td> <td>GND</td> <td></td> </tr> </table>	1	4.5V or more		2	0.1V or less		3	4.5V or more	detect		0.1V or less	undetected	4	GND	
1	-9V or more																				
2	GND																				
1	4.5V or more																				
2	0.1V or less																				
3	4.5V or more	detect																			
	0.1V or less	undetected																			
4	GND																				

► SOLUTION

1. TEST MODE → MOT TRAIN TEST
 - BIGWIN FND : Check "ON" display
 - TICKET FND : Check first digit change
 - CREDIT FND : Check the number of balls fired
2. CHECK :
 - 1) Assembling the motor, checking the assembly status of parts

- 2) Check the cable connection (P1,P2)
- 3) Check Part Deformation (P1)
- 4) Motor voltage measurement (P1)
- 5) MOTOR replacement
- 6) Sensor PCB voltage measurement (P2)
- 7) SENSOR PCB replacement
- 8) MAIN PCB replacement

PART NAME	CODE	PART NAME	CODE
MOTOR	MZZZ0MOT170	PHOTO INT-1 PCB ASS'Y	AZZZ0PCB103
MAIN I/O PCB ASS'Y	AGOT0ASS001		

13) BALL IN SENSOR ERROR (Er.61)

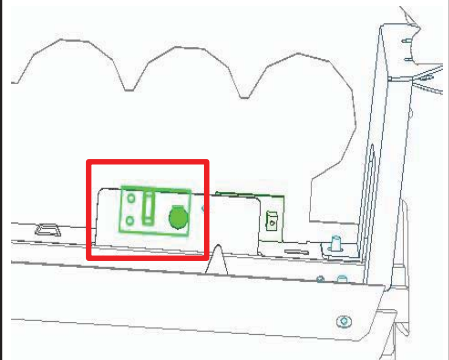
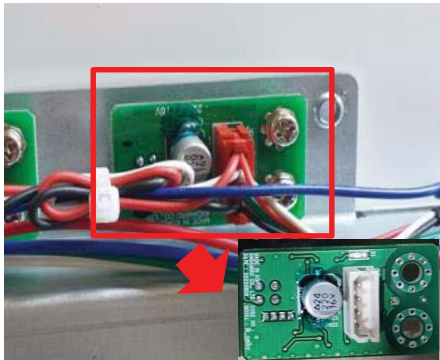
ERROR or LOCATION	P1	P2																											
		<table border="1"> <tr> <td>1</td> <td></td> <td></td> </tr> <tr> <td>2</td> <td></td> <td></td> </tr> <tr> <td>3</td> <td></td> <td></td> </tr> <tr> <td>4</td> <td></td> <td></td> </tr> </table> <table border="1"> <tr> <td>1</td> <td>4.5V or more</td> <td></td> </tr> <tr> <td>2</td> <td>0.1V or less</td> <td></td> </tr> <tr> <td>3</td> <td>0.1V or less</td> <td>detect</td> </tr> <tr> <td></td> <td>4.5V or more</td> <td>undetected</td> </tr> <tr> <td>4</td> <td>GND</td> <td></td> </tr> </table>	1			2			3			4			1	4.5V or more		2	0.1V or less		3	0.1V or less	detect		4.5V or more	undetected	4	GND	
1																													
2																													
3																													
4																													
1	4.5V or more																												
2	0.1V or less																												
3	0.1V or less	detect																											
	4.5V or more	undetected																											
4	GND																												

► SOLUTION

1. TEST MODE → MOT SHOOTER TEST
 - TICKET FND : Check the second digit change
2. CHECK :
 - 1) make sure the ball is there
 - 2) If there's no ball, put the ball on top, clear the error, and retest.

- 3) Check cable & connector connection status (P1)
- 4) Sensor PCB voltage measurement (P2)
- 5) SENSOR PCB replacement
- 6) MAIN PCB replacement

PART NAME	CODE	PART NAME	CODE
38KHZ IR SENSOR PCB ASS'Y_NORMAL	ASBT0PCB007	MAIN I/O PCB ASS'Y	AGOT0ASS001

14) BALL OUT SENSOR ERROR (Er.62)

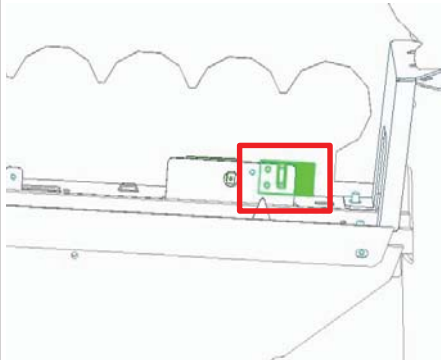
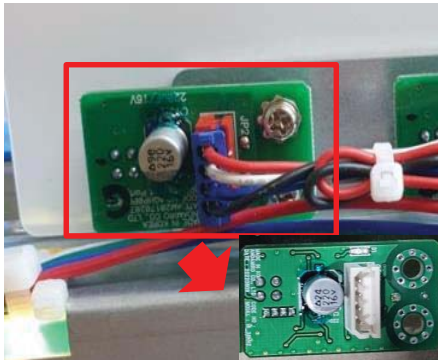
ERROR or LOCATION	P1	P2									
		<table border="1"> <tr><td>1</td><td></td></tr> <tr><td>2</td><td></td></tr> <tr><td>3</td><td></td></tr> <tr><td>4</td><td></td></tr> </table>	1		2		3		4		
1											
2											
3											
4											
		1	4.5V or more								
		2	0.1V or less								
		3	0.1V or less	detect							
			4.5V or more	undetected							
		4	GND								

► SOLUTION

1. TEST MODE → MOT SHOOTER TEST
 ► TICKET FND : 3rd digit change confirmation

2. CHECK :

- 1) Check if there is a ball jam, stagnant ball, or ball
- 2) If there's no ball, put the ball on top, clear the error, and retest.

- 3) Check cable & connector connection status (P1)
- 4) Sensor PCB voltage measurement (P2)
- 5) SENSOR PCB replacement
- 6) MAIN PCB replacement

PART NAME	CODE	PART NAME	CODE
38KHZ IR SENSOR PCB ASS'Y_NORMAL	ASBT0PCB007	MAIN I/O PCB ASS'Y	AGOT0ASS001

15) BALL RAIL SENSOR ERROR (Er.63)

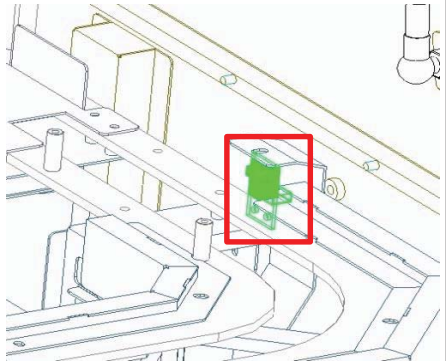
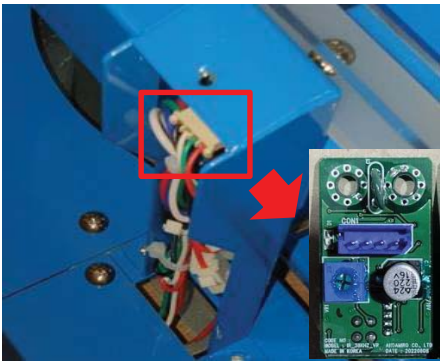
ERROR or LOCATION	P1	P2					
		<table border="1"> <tr><td>4</td><td>3</td><td>2</td><td>1</td></tr> </table>	4	3	2	1	
4	3	2	1				
		1	4.5V or more				
		2	0.1V or less				
		3	0.1V or less	detect			
			4.5V or more	undetected			
		4	GND				

► SOLUTION

1. TEST MODE → INPUT TEST
 ► Speaker sound upon sensor recognition: 7

2. CHECK :

- 1) Check if there is a ball jam, stagnant ball, or ball
- 2) Check cable & connector connection status (P1)

- 3) Check part deformation
- 4) Sensor PCB voltage measurement (P2)
- 5) Proceed through the calibration mode specified in the manual in order
- 6) SENSOR PCB replacement
- 7) MAIN PCB replacement

PART NAME	CODE	PART NAME	CODE
38KHZ IR SENSOR PCB VR ASS'Y_3CM	ASBT0PCB009	MAIN I/O PCB ASS'Y	AGOT0ASS001

16) BALL SUCCESS SENSOR ERROR (Er.64)

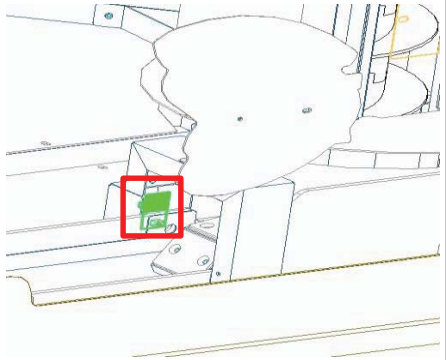
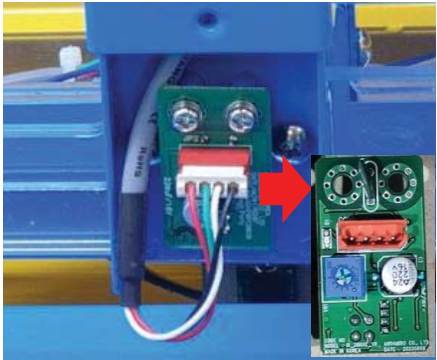
ERROR or LOCATION	P1	P2	
		1	
		2	
		3	
		4	
		1	4.5V or more
		2	0.1V or less
		3	0.1V or less detect
			4.5V or more undetected
		4	GND

► SOLUTION			
<p>1. TEST MODE → INPUT TEST ► Speaker sound upon sensor recognition: 6</p> <p>2. CHECK :</p> <p>1) Check for foreign objects and balls</p> <p>2) Check cable & connector connection status (P1)</p>		<p>3) Check part deformation</p> <p>4) Sensor PCB voltage measurement (P2)</p> <p>5) Proceed through the calibration mode specified in the manual in order</p> <p>6) SENSOR PCB replacement</p> <p>7) MAIN PCB replacement</p>	
PART NAME	CODE	PART NAME	CODE
38KHZ IR SENSOR PCB VR ASS'Y_2CM	ASBT0PCB008	MAIN I/O PCB ASS'Y	AGOT0ASS001

17) BALL SUCCESS RECOGNITION SENSOR CHEATING ERROR (Er.80)

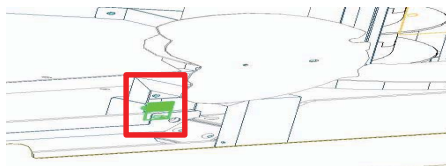
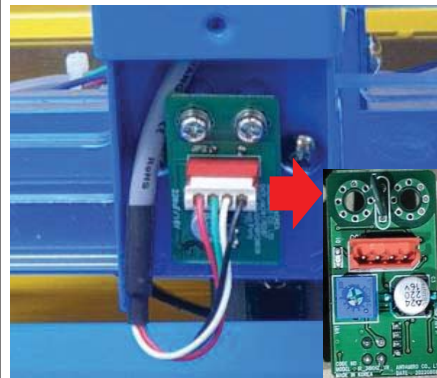
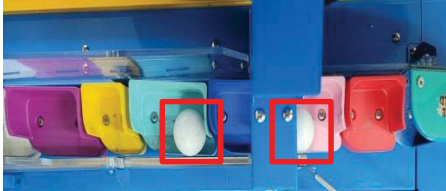
ERROR or LOCATION	P1	P2	
		1	
		2	
		3	
		4	
		1	4.5V or more
		2	0.1V or less
		3	0.1V or less detect
			4.5V or more undetected
		4	GND

► SOLUTION			
<p>1. TEST MODE → INPUT TEST ► Speaker sound upon sensor recognition: 6</p> <p>2. CHECK :</p> <p>1) Check if there are two balls in the entire train car</p> <p>2) Check cable & connector connection status (P1)</p>		<p>3) Check part deformation</p> <p>4) Sensor PCB voltage measurement (P2)</p> <p>5) Proceed through the calibration mode specified in the manual in order</p> <p>6) SENSOR PCB replacement</p> <p>7) MAIN PCB replacement</p>	
PART NAME	CODE	PART NAME	CODE
38KHZ IR SENSOR PCB VR ASS'Y_2CM	ASBT0PCB008	MAIN I/O PCB ASS'Y	AGOT0ASS001

18) TICKET ERROR (HELP)

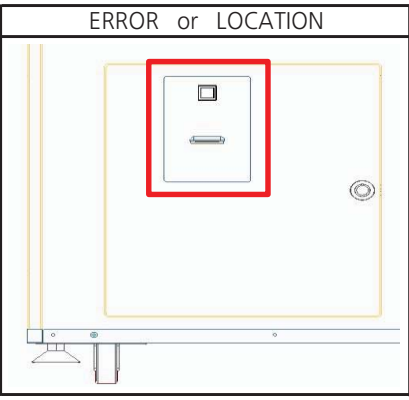
ERROR or LOCATION		► SOLUTION	
		<p>1. TEST MODE → TICKET TEST</p> <p>2. CHECK :</p> <p>1) Check whether TICKET JAM</p> <p>2) Check the cable connection status</p> <p>3) REPLACE TICKET DISPENSER</p> <p>4) MAIN PCB replacement</p>	
		PART NAME	CODE
TICKET DISPENSER	MZZZ0TID010	MAIN I/O PCB ASS'Y	AGOT0ASS001

19) VIDEO BOARD VERSION ERROR (Er.22)

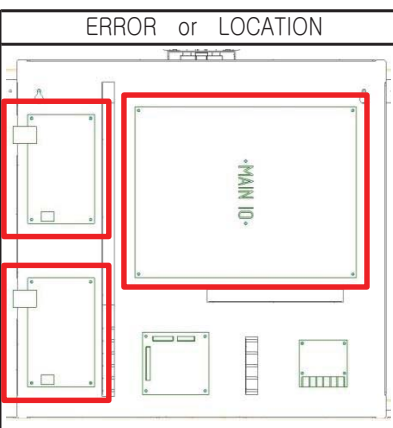
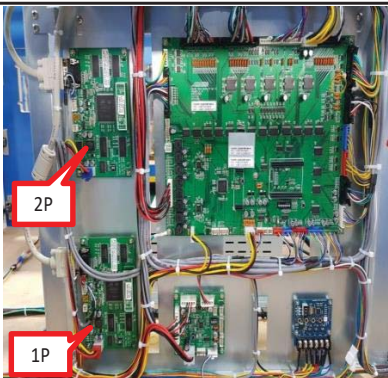
ERROR or LOCATION	P1	P2
		

► SOLUTION			
<p>1. CHECK :</p> <p>1) VIDEO, MAIN PCB cable connection check</p> <p>2) Check the version information again in BOOKKEEPING DATA</p>		<p>3) VIDEO PCB replacement in wrong version information play zone</p> <p>4) MAIN PCB Replacement</p>	
PART NAME	CODE	PART NAME	CODE
VIDEO PCB ASS'Y_EAGLE	AGOT0PCB005	MAIN I/O PCB ASS'Y	AGOT0ASS001

9 EXPLODED VIEW

1) MAIN CABINET ASS'Y

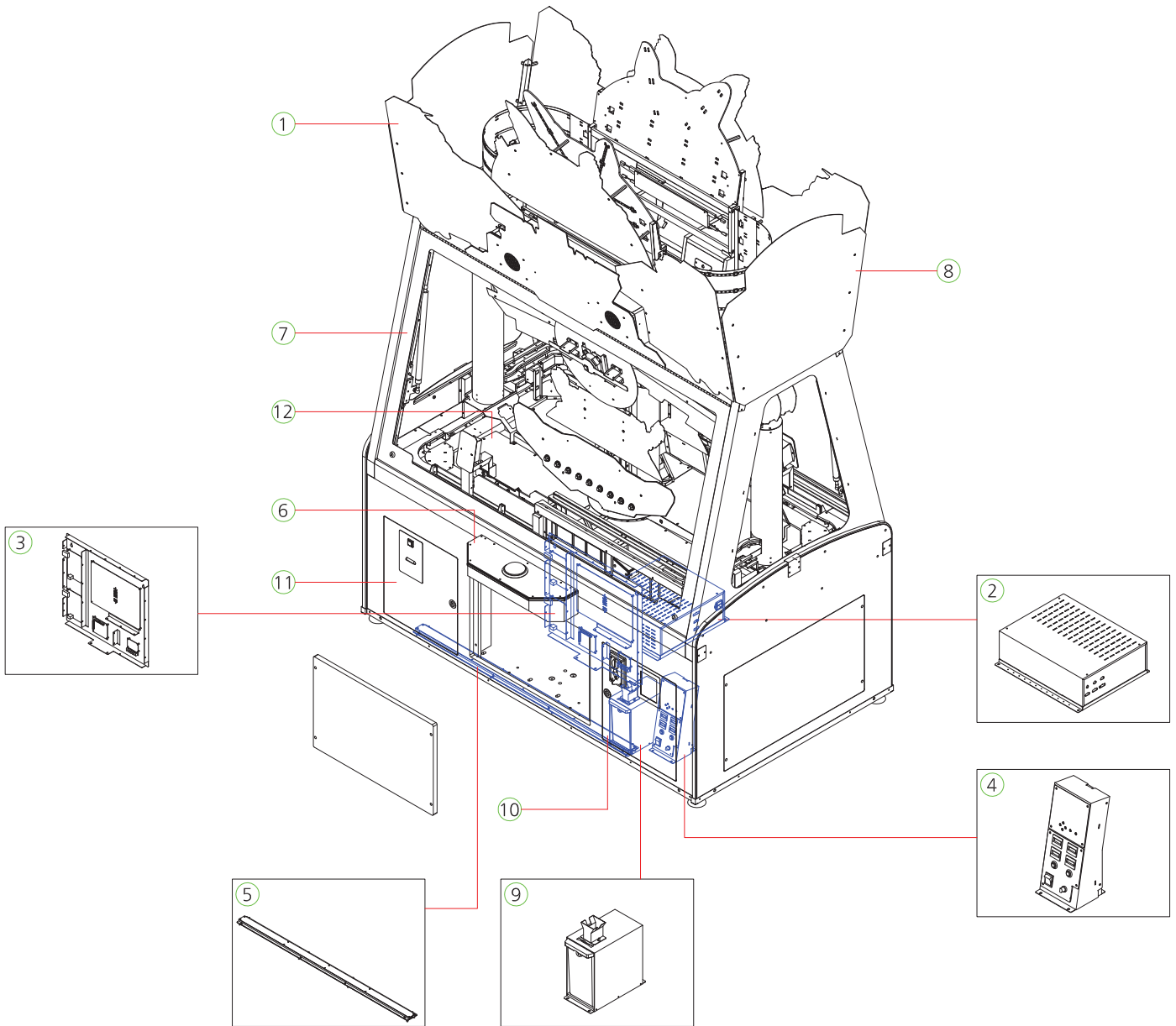

NO.	PART NAME	SPEC.	QUANTITY	CODE NO.
1	BILLBOARD PART	-	1	-
2	POWER SMPS BOX PART	-	1	-
3	MAIN BOARD PART	-	1	-
4	CONTROL PANEL TOTAL PART	-	1	-
5	CABINET BOTTOM LED PART	-	2	-
6	BUTTON TOTAL PART	-	1	-
7	CABINET DOOR TOTAL PART	-	1	-
8	BILLBOARD SIDE POP PART	-	2	-
9	COIN BOX PART	-	2	-
10	CABINET COIN DOOR PART	-	2	-
11	CABINET TICKET DOOR PART	-	2	-
12	GAME PLAYFIELD TOTAL PART	-	1	-

2) BILLBOARD PART

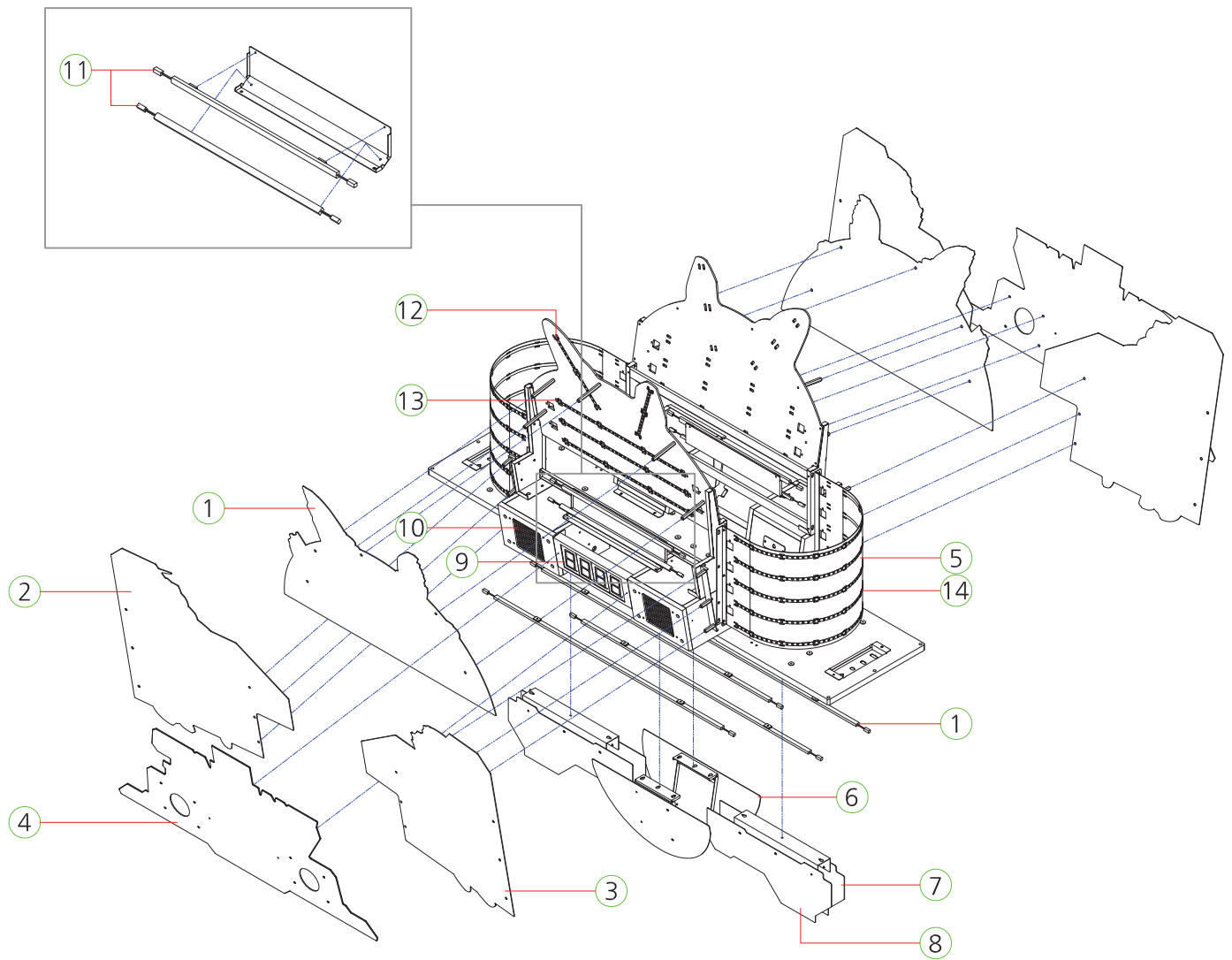

NO.	PART NAME	SPEC.	QUANTITY	CODE NO.
1	BILLBOARD TITLE COVER ACRYL	PET-2.0t	1	MGOT0ACR011
2	BILLBOARD DECO ACRYL-L	PET-2.0t	1	MGOT0ACR008
3	BILLBOARD DECO ACRYL-R	PET-2.0t	1	MGOT0ACR009
4	BILLBOARD BIGWIM FND COVER ACRYL	ACRYL-2.7t	1	MGOT0ACR004
5	BILLBOARD SIDE FLEXIBLE LED PET ACRYL	PET-1.0t	1	MGOT0ACR033
6	BILLBOARD BLS TOP COVER ACRYL	PET-1.5t	2	MGOT0ACR005
7	BILLBOARD CENTER DECO ACRYL-L	PET-1.5t	2	MGOT0ACR006
8	BILLBOARD CENTER DECO ACRYL-R	PET-1.5t	2	MGOT0ACR007
9	FND PCB ASS'Y	6390-4(STRAIGHT)	1	AFND0PCB011
10	SPEAKER	MID4.5"+TW1/2" 8Ω	2	MZZZ0SPE021
11	LED BAR 12V ASS'Y	460mm	2	AZZZ0PCB124
12	FLEX_T5050_WHITE_250_NWP_L_15	T5050 TOP300, 15	4	MELE0LED133
13	FLEX_T5050_WHITE_550_NWP_LR_33	T5050 TOP300, 33	6	MELE0LED112
14	FLEX_T5050_WHITE_700_NWP_LR_42	42	10	MELE0LED026

3) POWER SMPS BOX PART

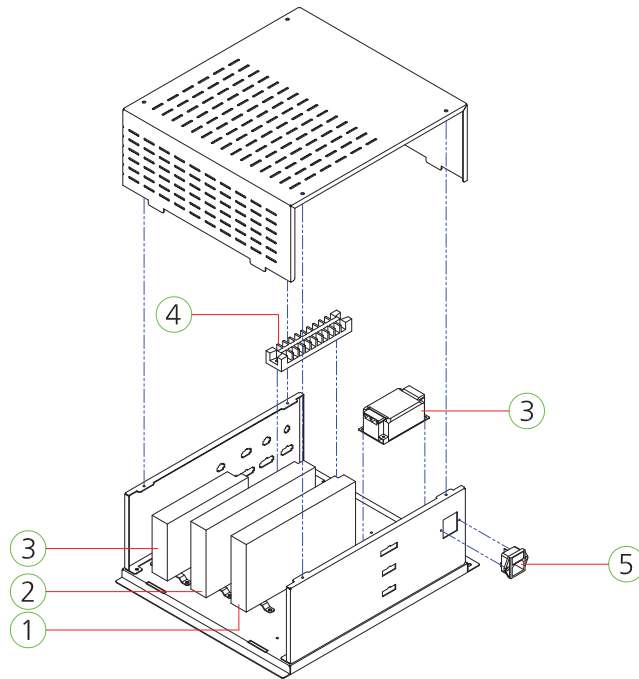

NO.	PART NAME	SPEC.	QUANTITY	CODE NO.
1	POWER SMPS	LRS-350-12V	1	MELE0SMP148
2	POWER SMPS	RSP-320-12V	1	MELE0SMP109
3	POWER SMPS	LRS-150F-5V	1	MELE0SMP096
4	NOISE FILTER	RNS-2010	1	MELE0NOI009
5	TERMINAL BLOCK	250V 10P UL_CE	1	MELE0TEB003
6	AC INPUT	DAC-13H, WITH FUSE10A_2EA	1	AELE0FUS002

4) MAIN BOARD PART

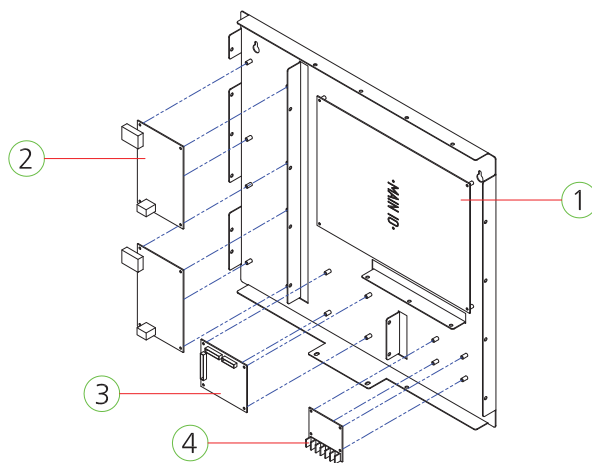

NO.	PART NAME	SPEC.	QUANTITY	CODE NO.
1	MAIN IO PCB ASS'Y	WITH CPU SOUND	1	AGOT0ASS001
2	VIDEO PCB ASS'Y_EAGLE	WITH MEMORY	2	AGOT0PCB005
3	WS2812B IO PCB ASS'Y	V3_1	1	AGOT0PCB006
4	RGB PWM PCB ASS'Y	RGB_CTRL -G2G5TC0131	1	MZZZ0000629

5) CONTROL PANEL TOTAL PART

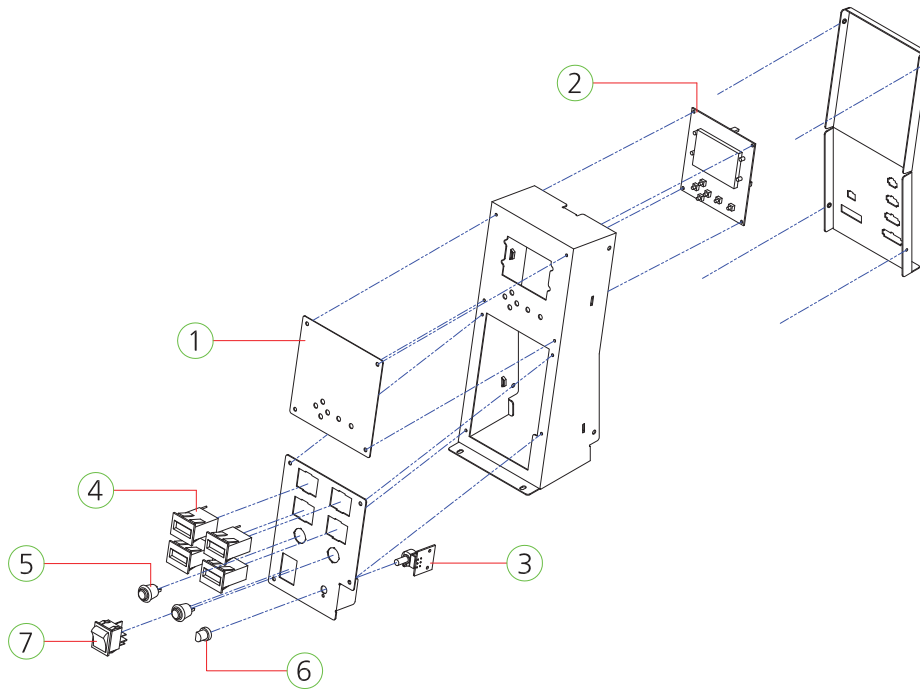

NO.	PART NAME	SPEC.	QUANTITY	CODE NO.
1	CONTROL PANEL COVER ACRYL	PET-1.0t	1	MGOT0ACR031
2	SETUP LCD PCB ASS'Y	-	1	AZZZ0PCB113
3	VOLUME PCB ASS'Y	1 VOLUME	1	AHM20PCB016
4	COUNTER	OA127CL W/2P CONNECTOR _20CM WIRE	4	MZZZ0COU002
5	PUSH BUTTON SWITCH	DS-412R_ROSH	1	MELE0PUS006
6	VOLUME KNOB	-	2	MELE0VOL007
7	ROCKER SWITCH	T-125 4P	1	MELE0SWI004

6) CABINET BOTTOM LED PART

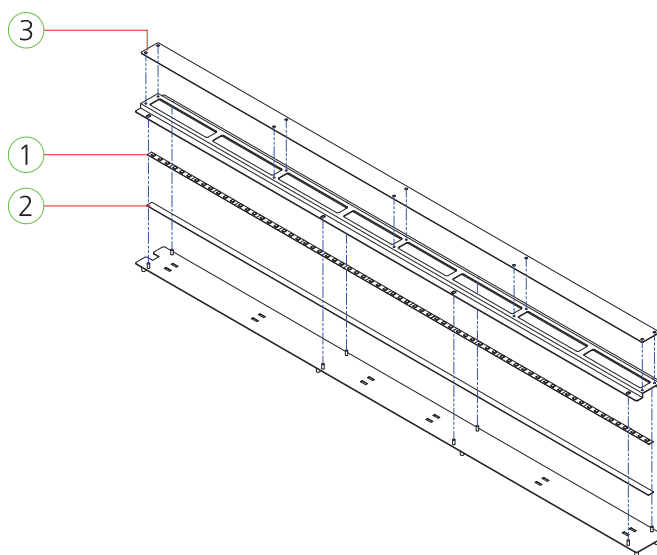

NO.	PART NAME	SPEC.	QUANTITY	CODE NO.
1	CABINET BOTTOM LED COVER ACRYL	PET-1.0t	1	MSBT0ACR013
2	CABINET BOTTOM FLEXIBLE LED PET ACRYL	PET-1.0t	1	MSBT0ACR012
3	FLEX_RGB_1150_NWP_L_69	T5050 TOP 300, 69	1	MELE0LED102

7) BUTTON TOTAL PART

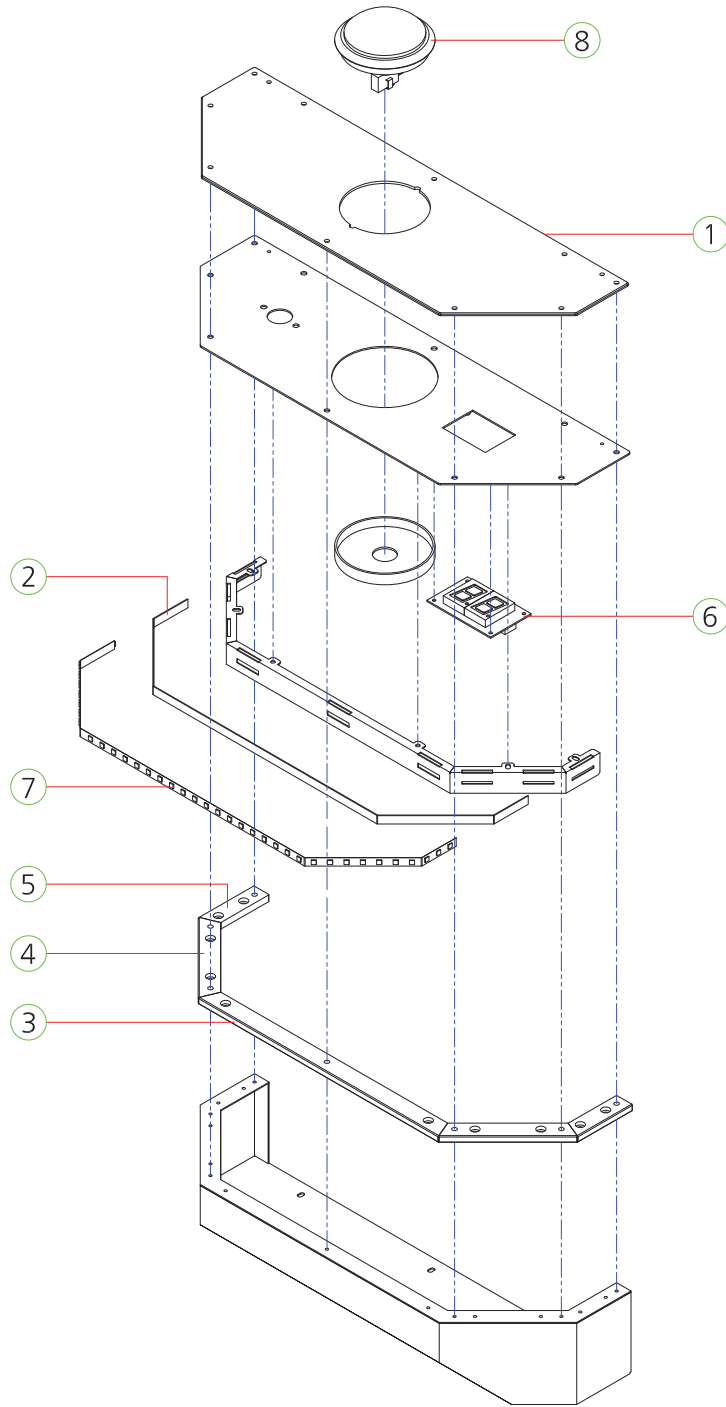

NO.	PART NAME	SPEC.	QUANTITY	CODE NO.
1	CABINET BUTTON LED COVER ACRYL	ACRYL-2.7t	1	MGOT0ACR012
2	CABINET BUTTON FLEXIBLE LED PET ACRYL	PET-1.0t	1	MSBT0ACR014
3	CABINET BUTTON LED FRONT ACRYL	ACRYL-8.0t	1	MSBT0ACR016
4	CABINET BUTTON LED ANGLE ACRYL	ACRYL-8.0t	2	MSBT0ACR015
5	CABINET BUTTON LED SIDE ACRYL-L	ACRYL-8.0t	2	MSBT0ACR017
6	FND PCB ASS'Y	2941-2(STRAIGHT)	2	AFND0PCB003
7	FLEX_RGB_600_NWP_L_36	T5050 TOP 300, 36	1	MELE0LED101
8	BUTTON SWITCH	CWB 401 -WHITE 100MM LED	1	MZZZ0BUT080

8) CABINET DOOR TOTAL PART

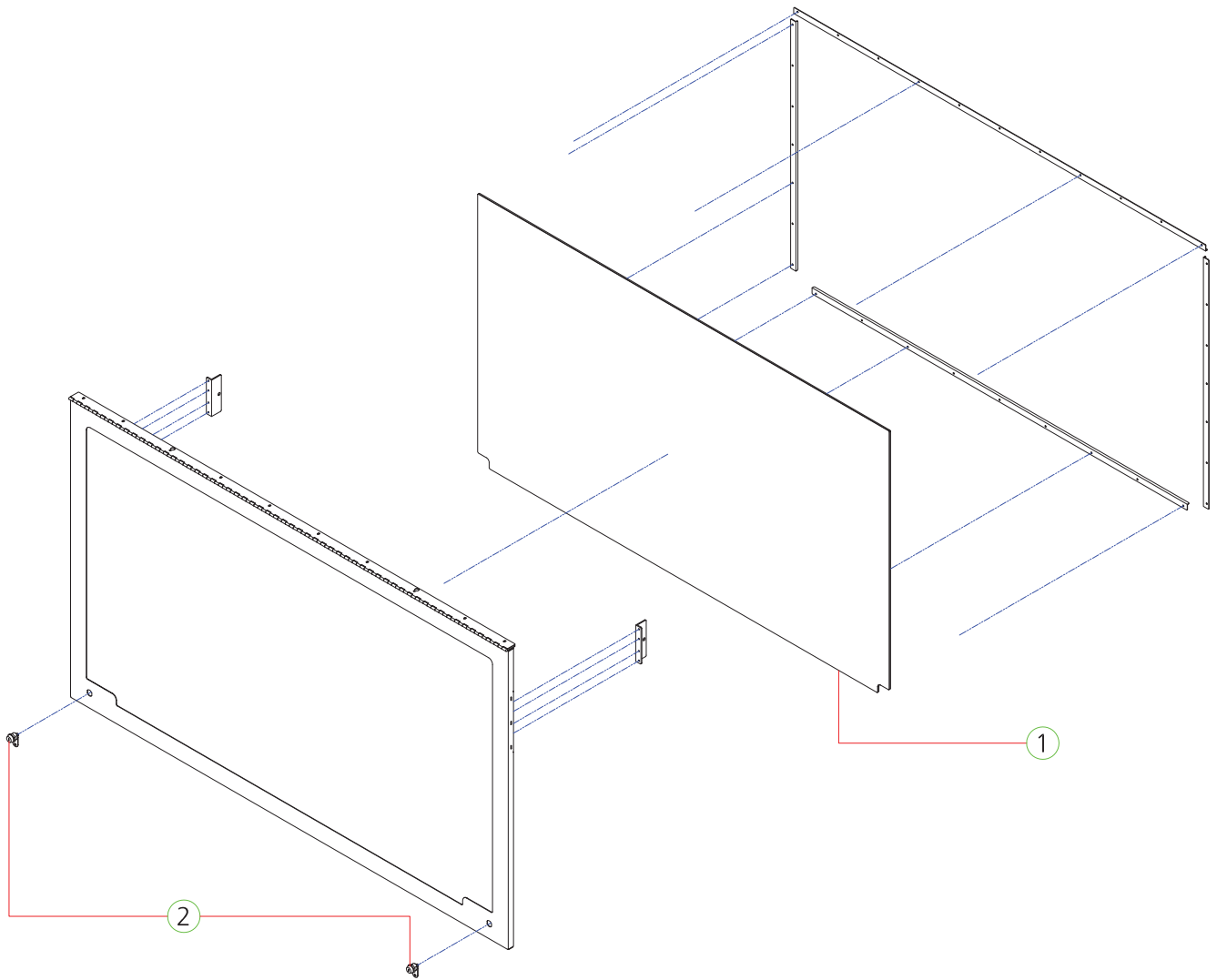

NO.	PART NAME	SPEC.	QUANTITY	CODE NO.
1	CABINET DOOR GLASS	GLASS-5.0t	1	MSBT0GLA001
2	KEY ASS'Y	7001	2	MZZZ0KEY076

9) BILLBOARD SIDE POP PART

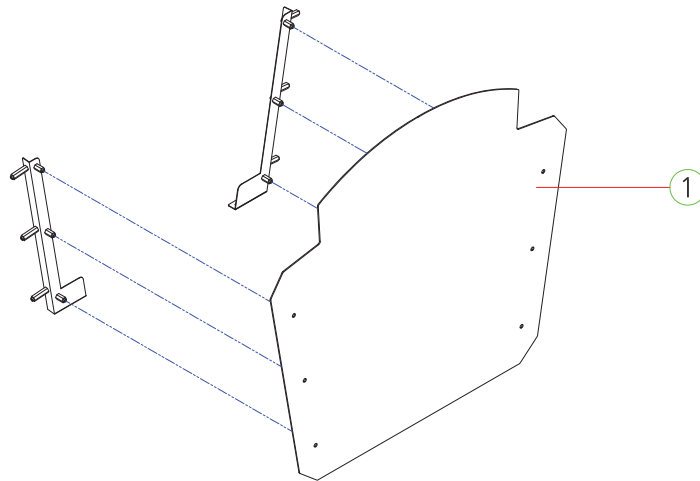

NO.	PART NAME	SPEC.	QUANTITY	CODE NO.
1	BILLBOARD SIDE POP COVER ACRYL	PET-2.0t	1	MGOT0ACR010

10) COIN BOX PART

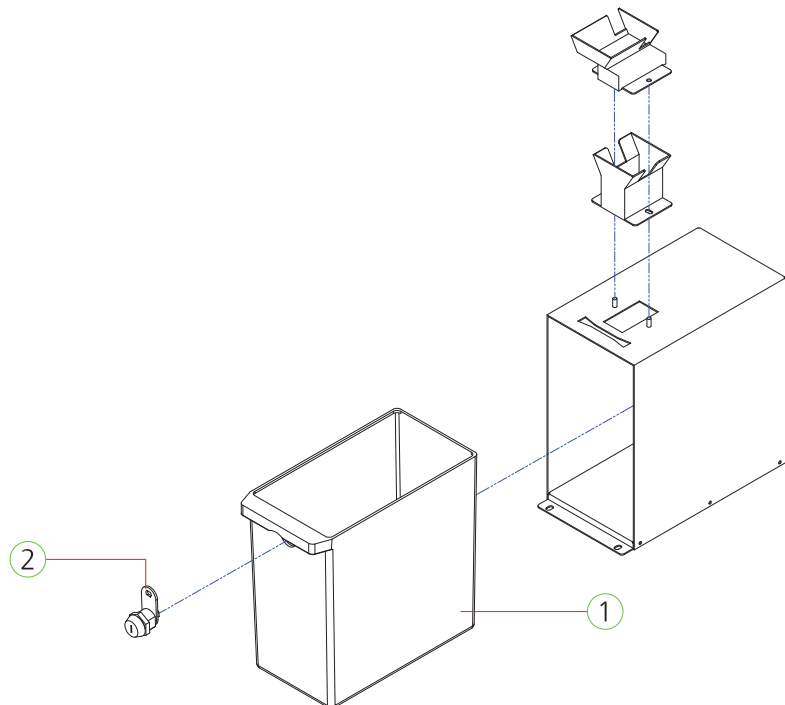

NO.	PART NAME	SPEC.	QUANTITY	CODE NO.
1	[OPTION] COIN BOX SMALL	200*198*107 BLACK	1	MDRE0PLA007
2	[OPTION] KEY ASS'Y	6001	1	MGOT0ACR008

11) CABINET COIN DOOR PART

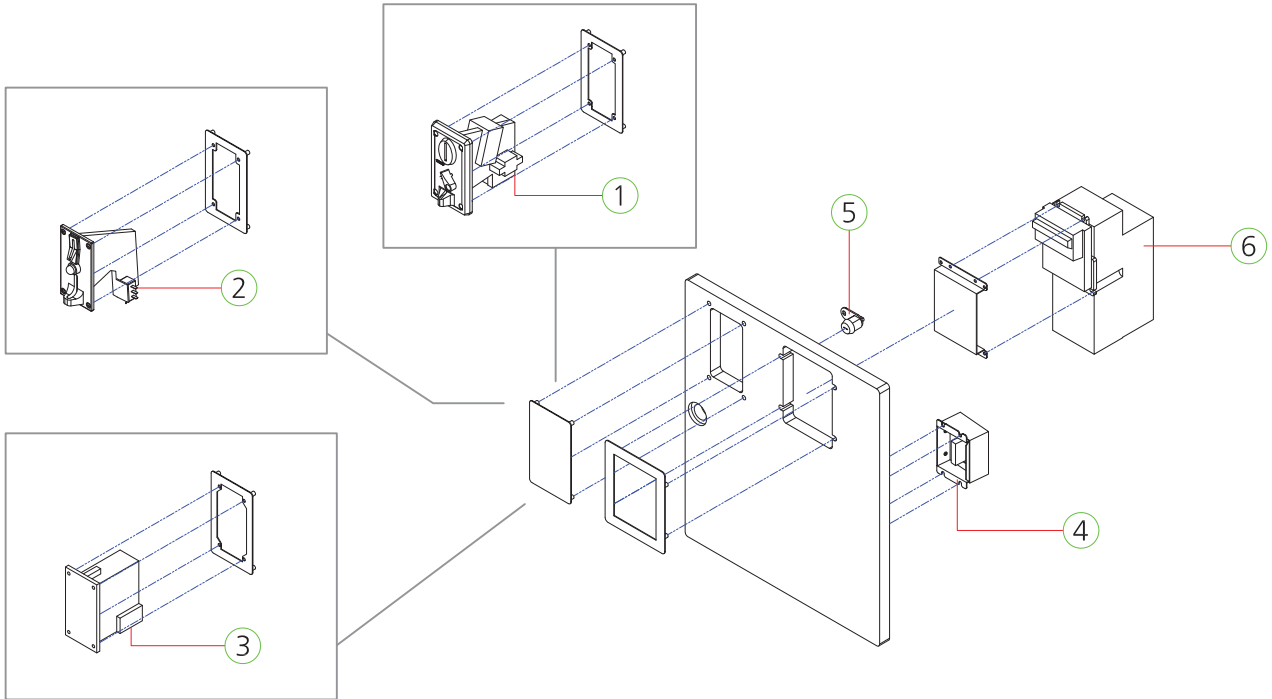

NO.	PART NAME	SPEC.	QUANTITY	CODE NO.
1	COIN SELECTOR	TW-389	1	MZZZ0COS052
2	[OPTION] CEC COIN SELECTOR	CEC HS-03CS+SWITCH	1	MZZZ0COS028
3	[OPTION] NAMCO COIN SELECTOR	-	1	-
4	MEI ACCEPTOR RELAY		1	-
5	KEY ASS'Y	7001	1	MZZZ0KEY076
6	[OPTION] BILL ACCEPT	-	1	-

12) CABINET TICKET DOOR PART

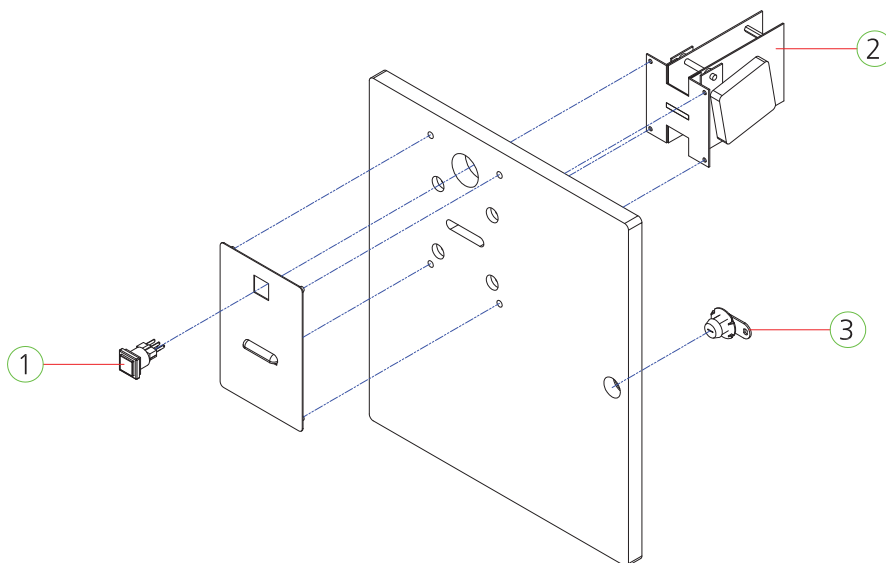

NO.	PART NAME	SPEC.	QUANTITY	CODE NO.
1	BUTTON SWITCH	TICKET AM1PB-26SH R12D	1	MMUM0BUT002
2	[OPTION] TICKET DISPENSER	CLE CL-002Q_ 270 HIGH SPEED	1	MZZZ0TID010
3	KEY ASS'Y	7001	1	MZZZ0KEY076

13) GAME PLAYFIELD TOTAL PART

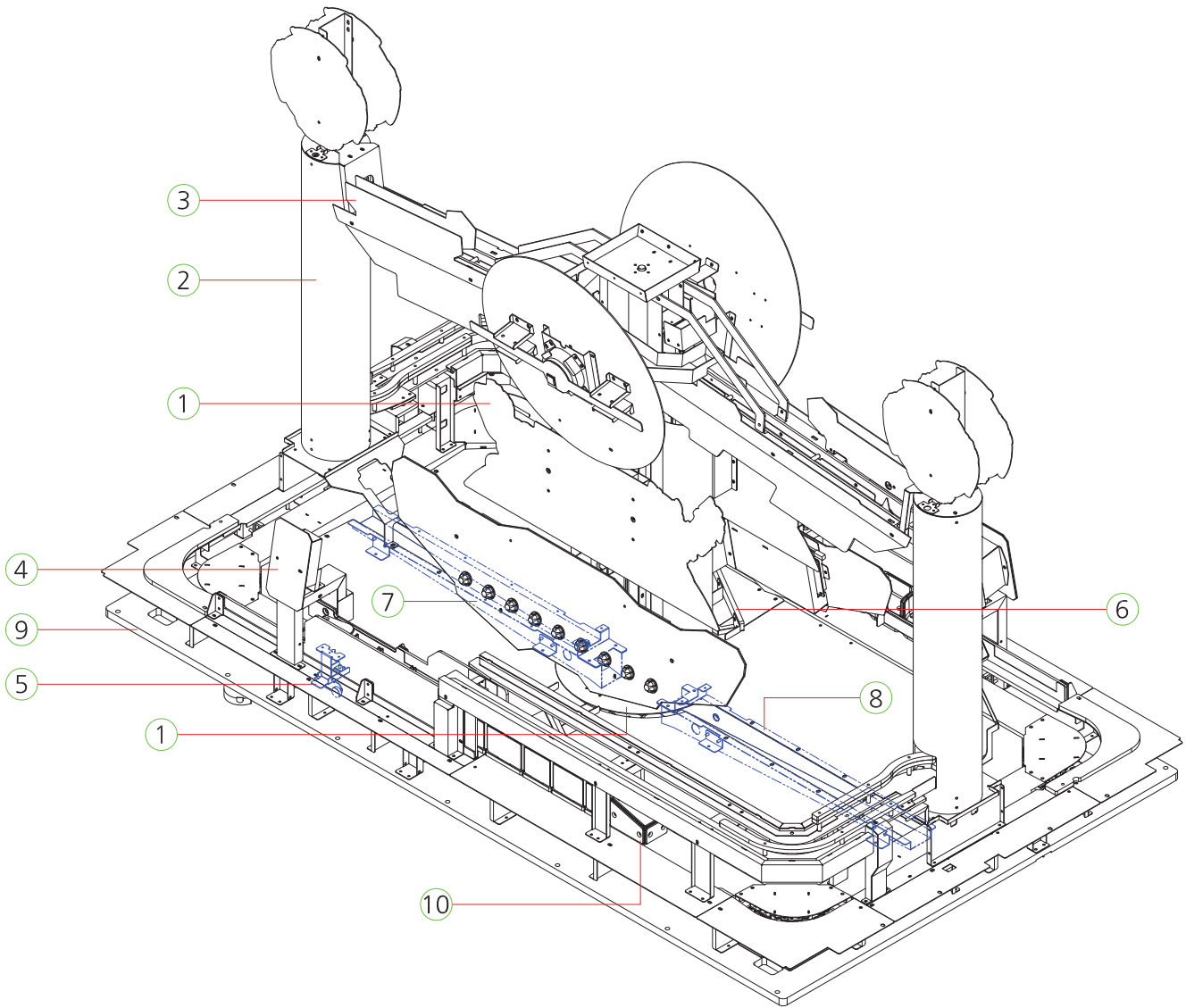

NO.	PART NAME	SPEC.	QUANTITY	CODE NO.
1	BALL LIFT SCREW PART	-	2	-
2	BALL SCREW PIPE PART	-	2	-
3	UPPER RAIL PART	-	2	-
4	TRAIN SIDE FENCE PART	-	2	-
5	TRAIN ATTACH PART	-	22	-
6	PLAYFIELD FRONT BALL FENCE BKT PART	-	2	-
7	BALL RETURN CHUTE PART-L	-	2	-
8	BALL RETURN CHUTE PART-R	-	2	-
9	CHAIN MAIN PLATE PART	-	1	-
10	TRAIN TOTAL PART	-	2	-

(1) BALL LIFT SCREW PART

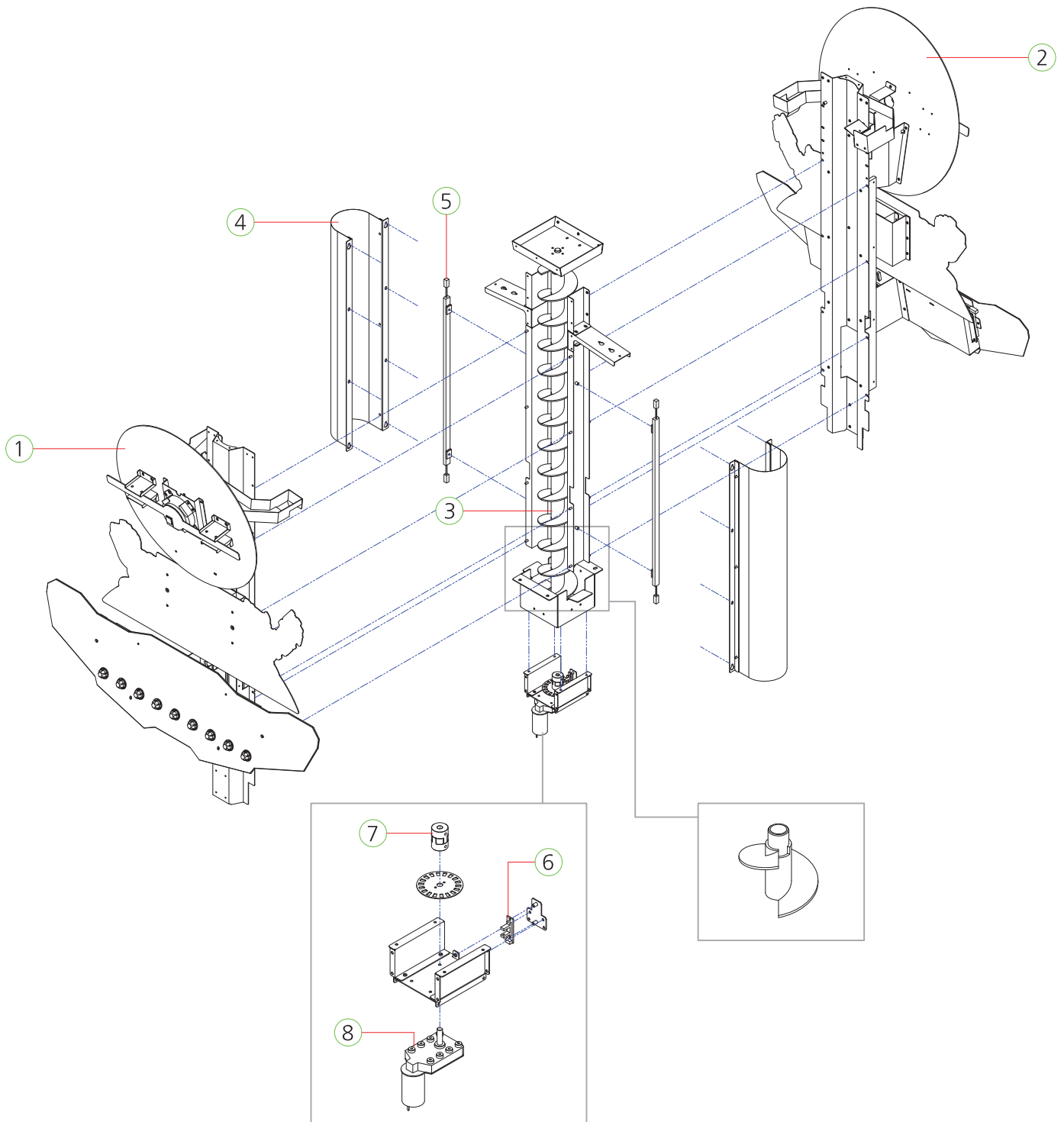

NO.	PART NAME	SPEC.	QUANTITY	CODE NO.
1	BALL LIFT SCREW MAIN PART-L	-	1	-
2	BALL LIFT SCREW MAIN PART-R	-	1	-
3	SCREW	PC ABS_BLACK	1	MDOS0PLA001
4	BALL LIFT SCREW SIDE COVER ACRYL	-	2	MGOT0SHE001
5	LED BAR_460mm	-	2	AZZ0PCB124
6	PHOTO-INT1 PCB ASS'Y	-	1	AZZ0PCB103
7	COUPLING ASS'Y	CR050	2	AZZ0COP001
8	MOTOR	KGE-0116-ND3657 U1 (12V, 43rpm)	1	MZZ0MOT155

(2) BALL LIFT SCREW MAIN PART

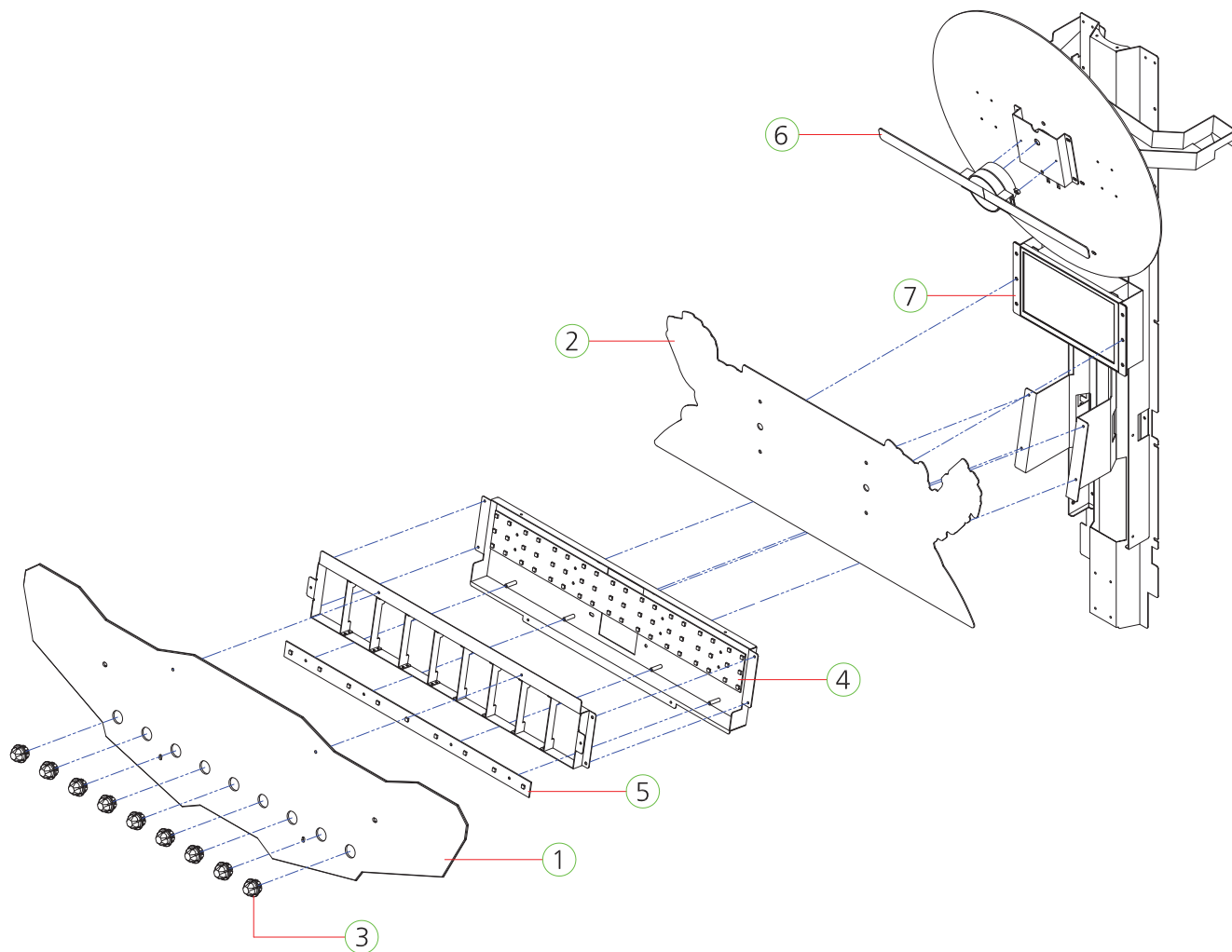

NO.	PART NAME	SPEC.	QUANTITY	CODE NO.
1	BALL LIFT SCREW TRAIN LED COVER ACRYL	ACRYL-2.7t	1	MGOT0ACR002
2	BALL LIFT SCREW MONITOR ACRYL	PET-1.5t	1	MGOT0ACR001
3	LED CAP	Φ20_CLEAR	1	MZZZ0PLA037
4	TRAIN SCORE LED PCB ASS'Y	-	1	ASBT0PCB003
5	TRAIN SCORE CAP LED PCB ASS'Y	PET-1.0t	1	MGOT0ACR033
6	LED FAN_3D HOLOGRAPHIC LED FAN	-	1	MZZZ0ETC086
7	MONITOR	8 INCH	1	MZZZ0LCD023

(3) BALL SCREW PIPE PART

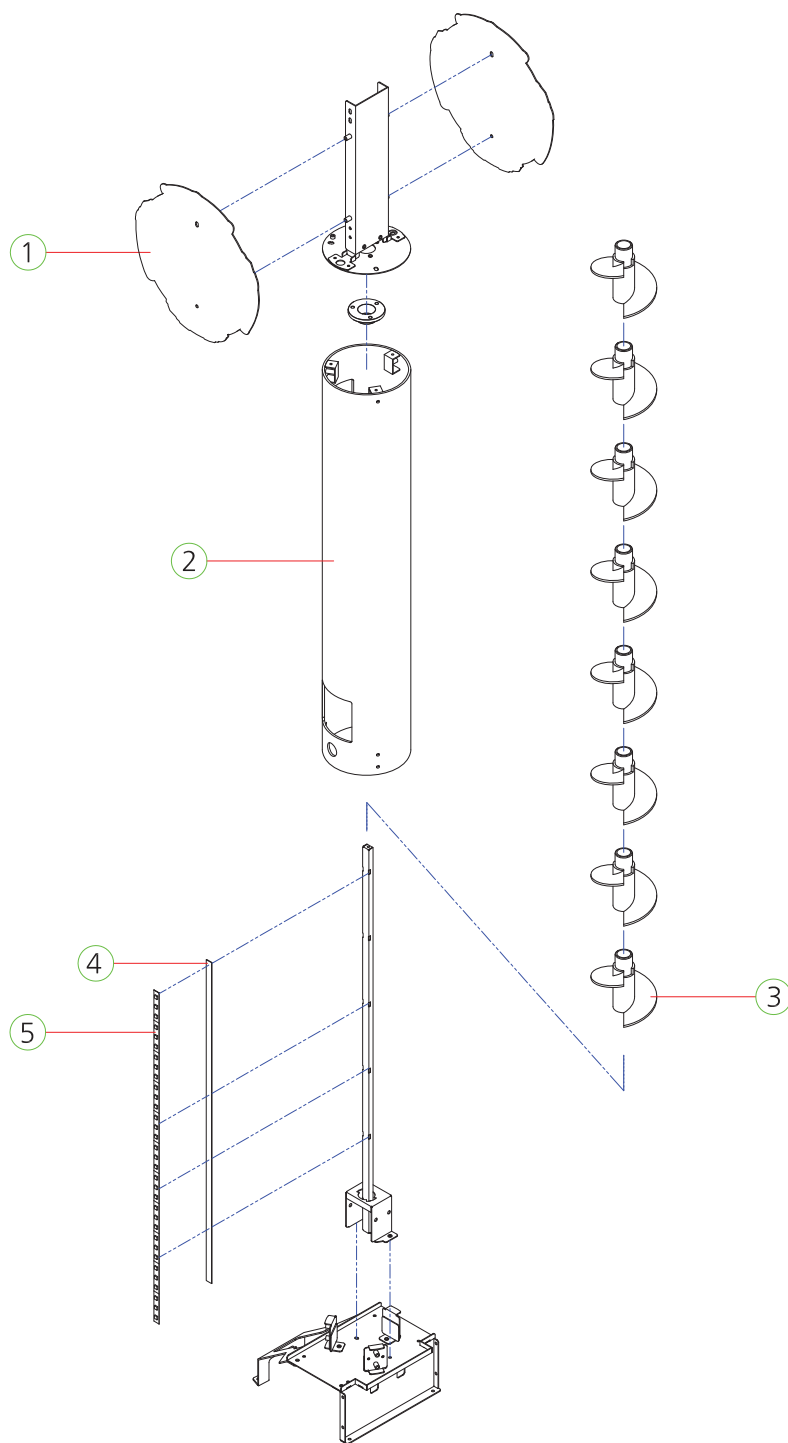

NO.	PART NAME	SPEC.	QUANTITY	CODE NO.
1	BILLBOARD TITLE COVER ACRYL	PET-2.0t	2	MGOT0ACR011
2	BALL SCREW PIPE UPPER ACRYL	PET-1.5t	1	MSBT0ACR009
3	MOLD_SCREW_ACETAL	ACETAL	8	MSBT0PLA001
4	BALL SCREW PIPE INNER FLEXIBLE LED PET ACRYL	PET-1.0t	1	MSBT0ACR010
5	FLEXIBLE LED PCB	FLAT LED PCBx566	1	-

(4) UPPER RAIL PART

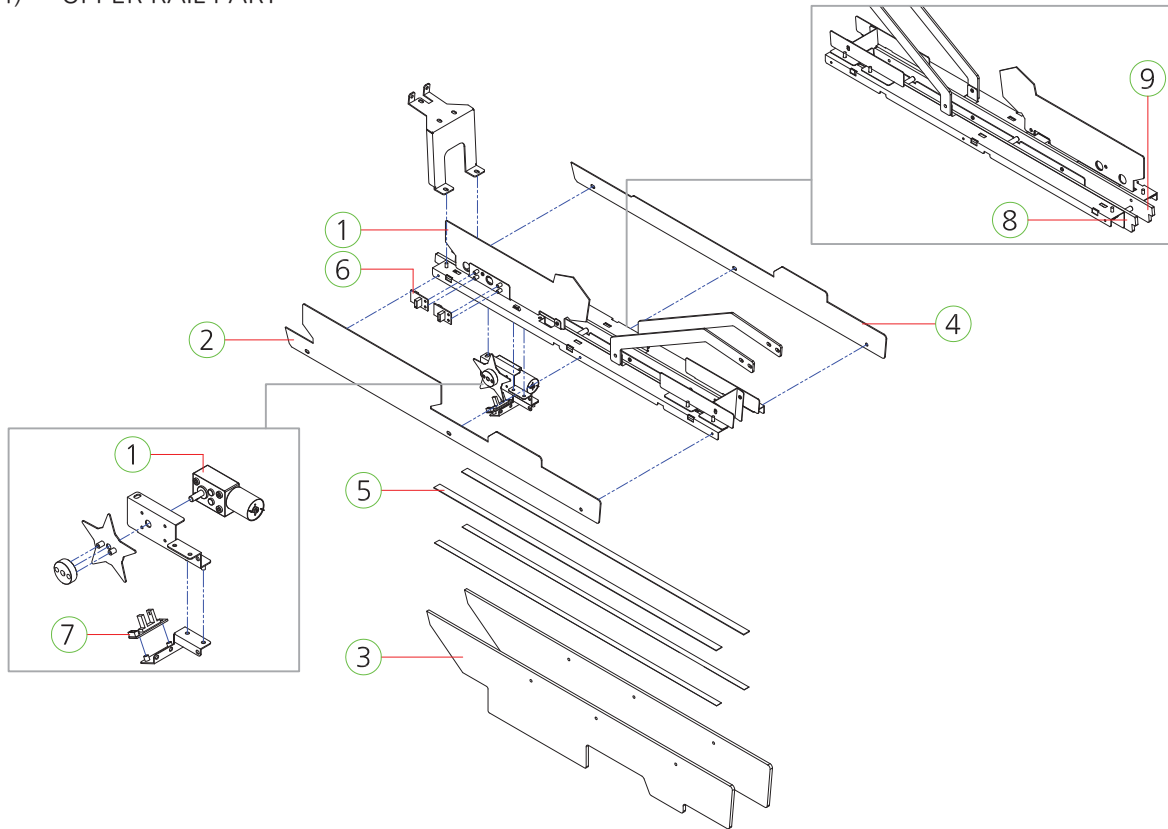

NO.	PART NAME	SPEC.	QUANTITY	CODE NO.
1	UPPER RAIL SENSOR COVER ACRYL	PET-1.5t	1	MGOT0ACR030
2	UPPER RAIL LED COVER ACRYL-R	PET-1.5t	1	MGOT0ACR027
3	UPPER RAIL LED DISPLAY ACRYL-L	ACRYL-4.7t	2	MGOT0ACR028
4	UPPER RAIL LED COVER ACRYL-L	PET-1.5t	1	MGOT0ACR026
5	UPPER RAIL FLEXIBLE LED PET ACRYL	PET-1.0t	2	MSBT0ACR030
6	IR SENSOR PCB ASS'Y_NORMAL	-	2	ASBT0PCB007
7	PHOTO-INT1 PCB ASS'Y	-	1	ACIROPCB011
8	UPPER RAIL ACRYL-L	PC-4.7t	1	MSBT0ACR028
9	UPPER RAIL ACRYL-R	PC-4.7t	1	MSBT0ACR029

(5) TRAIN SIDE FENCE PART

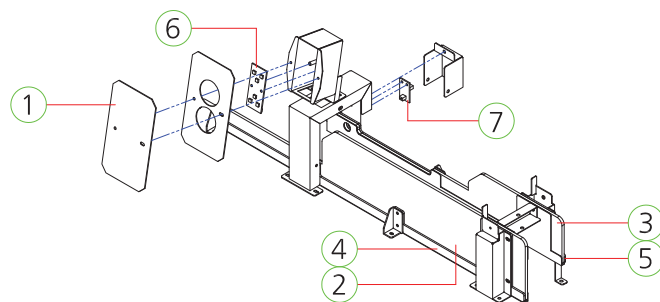

NO.	PART NAME	SPEC.	QUANTITY	CODE NO.
1	TRAIN BALL CHECK UPPER LED COVER ACRYL	ACRYL-1.5t	1	MGOT0ACR014
2	TRAIN FRONT FENCE ACRYL-A	ACRYL-4.7t	1	MSBT0ACR074
3	TRAIN FRONT FENCE ACRYL-B	ACRYL-4.7t	1	MGOT0ACR028
4	TRAIN FRONT FENCE INNER ACRYL-L	ACRYL-2.7t	1	MSBT0ACR026
5	TRAIN FRONT FENCE INNER ACRYL-R	ACRYL-2.7t	1	MSBT0ACR075
6	TRAIN BALL CHECK UPPER LED PCB ASS'Y	-	1	ATTT0PCB009
7	IR SENSOR PCB ASS'Y_2CM	38KHZ_CONNECTOR RED	1	ASBT0PCB008

(6) TRAIN ATTACH PART

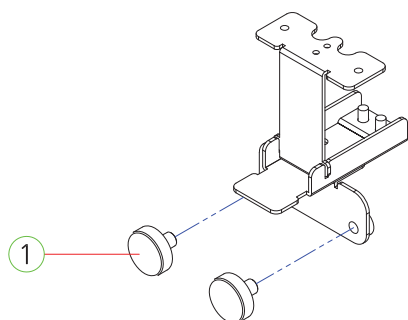

(7) PLAYFIELD FRONT BALL FENCE BKT PART

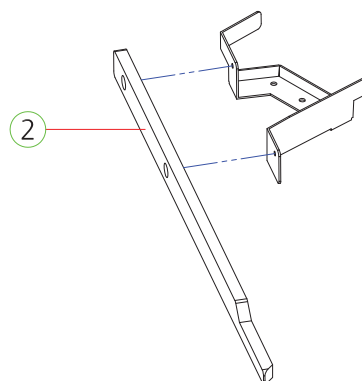

NO.	PART NAME	SPEC.	QUANTITY	CODE NO.
1	BEARING	DR-19B	1	MZZZ0BEA117
2	PLAYFIELD FRONT BALL FENCE ACRYL	ACRYL-8.0t	1	MSBT0ACR073

(8) BALL RETURN CHUTE PART-L

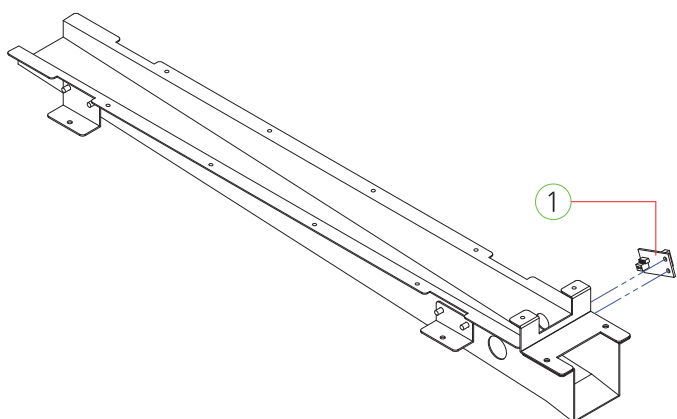

(9) BALL RETURN CHUTE PART-R

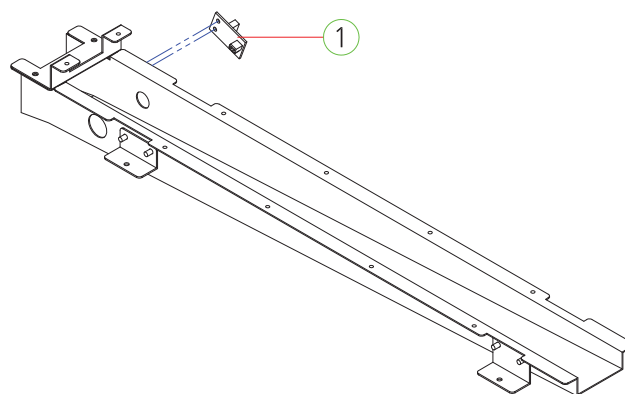

NO.	PART NAME	SPEC.	QUANTITY	CODE NO.	WARRANTY
1	IR SENSOR PCB ASS'Y_2CM	-	2	-	ASBT0PCB008

(10) CHAIN MAIN PLATE PART

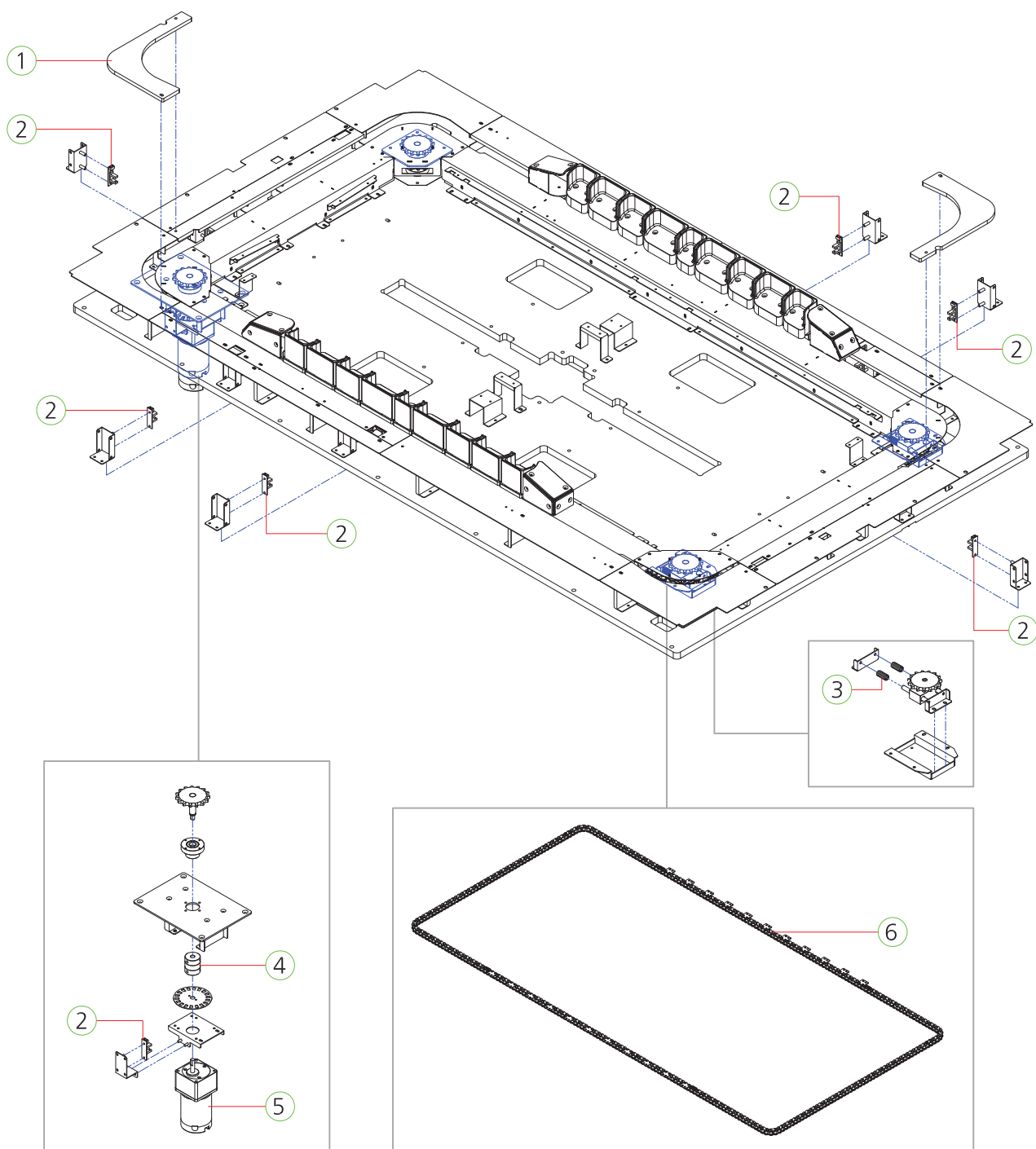

NO.	PART NAME	SPEC.	QUANTITY	CODE NO.
1	CHAIN GUIDE OUTER CORNER COVER ACRYL_1P	ACRYL-8.0t	2	MSBT0ACR071
2	PHOTO-INT1 PCB ASS'Y	ANGLE TYPE	7	AZZZ0PCB103
3	CONVEYOR TENSION SPRING	SUS304-1.2t	4	MDM30SPR001
4	COUPLING	JOC30	1	MZZZ0COP002
5	MOTOR	K6DG15N	1	MZZM0MOT016
	GEAR HEAD	K6G30C	1	MZZM0MOT019
6	CHAIN	RS40_328LINK (11ATTACHMENT)	1	MSBT0CHA001

(11) TRAIN TOTAL PART

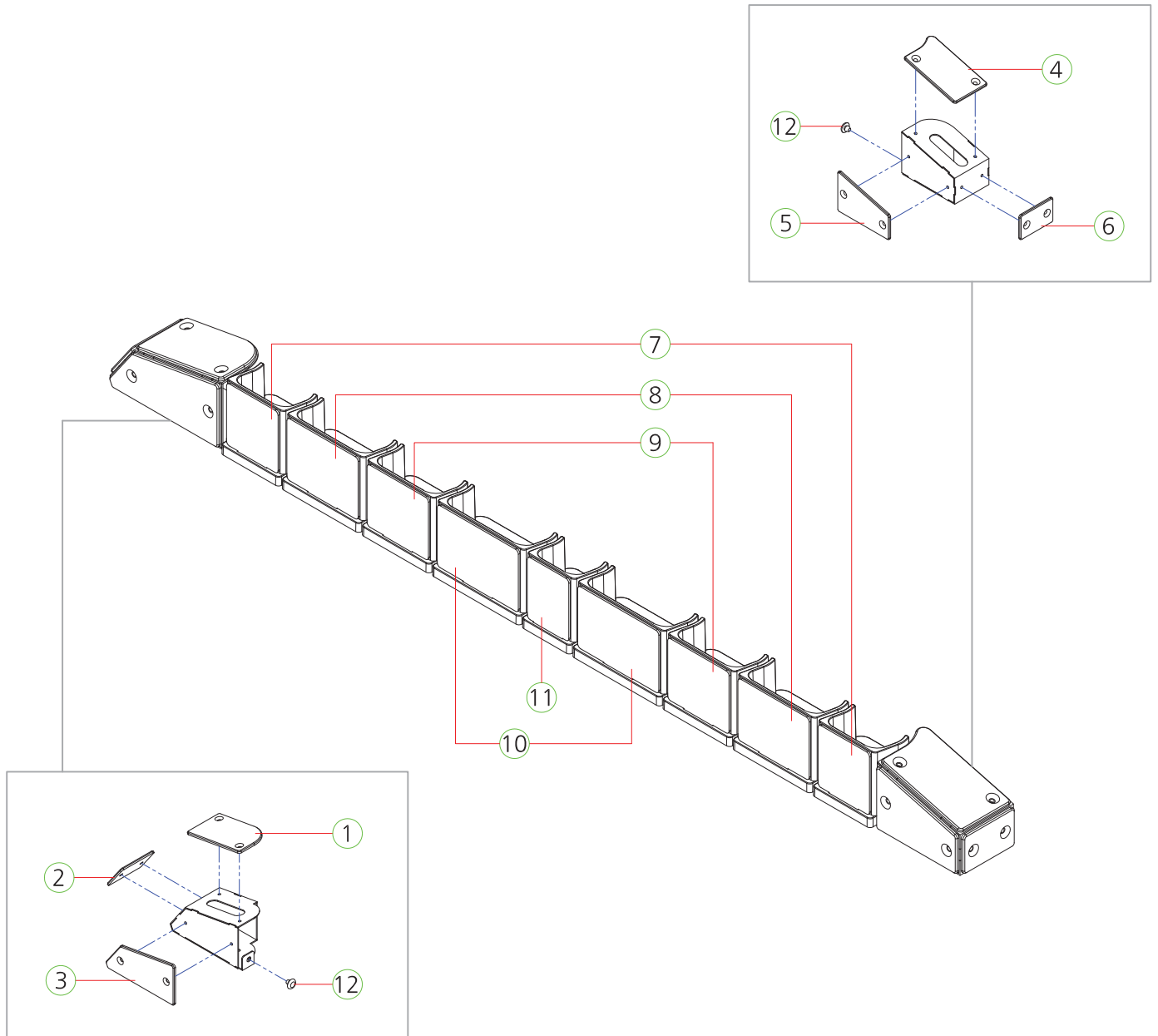

NO.	PART NAME	SPEC.	QUANTITY	CODE NO.
1	TRAIN HEAD TOP ACRYL-L	ACRYL-2.7t	1	MGOT0ACR019
2	TRAIN HEAD FRONTA ACRYL-L	ACRYL-2.7t	1	MGOT0ACR015
3	TRAIN HEAD SIDE ACRYL-L	ACRYL-2.7t	1	MGOT0ACR017
4	TRAIN HEAD TOP ACRYL-R	ACRYL-2.7t	1	MGOT0ACR020
5	TRAIN HEAD SIDE ACRYL-R	ACRYL-2.7t	1	MGOT0ACR018
6	TRAIN HEAD FRONT ACRYL-R	ACRYL-2.7t	1	MGOT0ACR016
7	TRAIN SIDE ACRYL-A	PET-1.5t	1	MGOT0ACR021
8	TRAIN SIDE ACRYL-B	PET-1.5t	1	MGOT0ACR022
9	TRAIN SIDE ACRYL-C	PET-1.5t	1	MGOT0ACR023
10	TRAIN SIDE ACRYL-D	PET-1.5t	1	MGOT0ACR024
11	TRAIN SIDE ACRYL-E	PET-1.5t	1	MGOT0ACR025
12	PLUG CUSHION RUBBER	[KD-96R-9] 6MM	2	MCIR0RUB001

10 PCB CONNETCOR LOCATION

► pin information

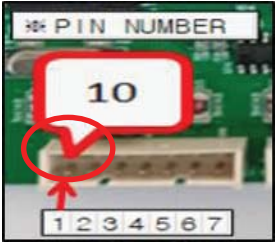
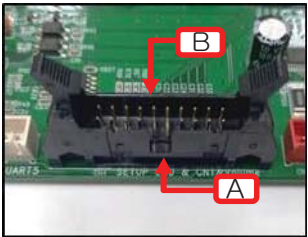
1	2	PIN DESCRIPTION
		<p>1. The arrow point means the contact pin number 1</p> <p>2. direction of Hirose connector</p>

1) MAIN I/O PCB ASS'Y

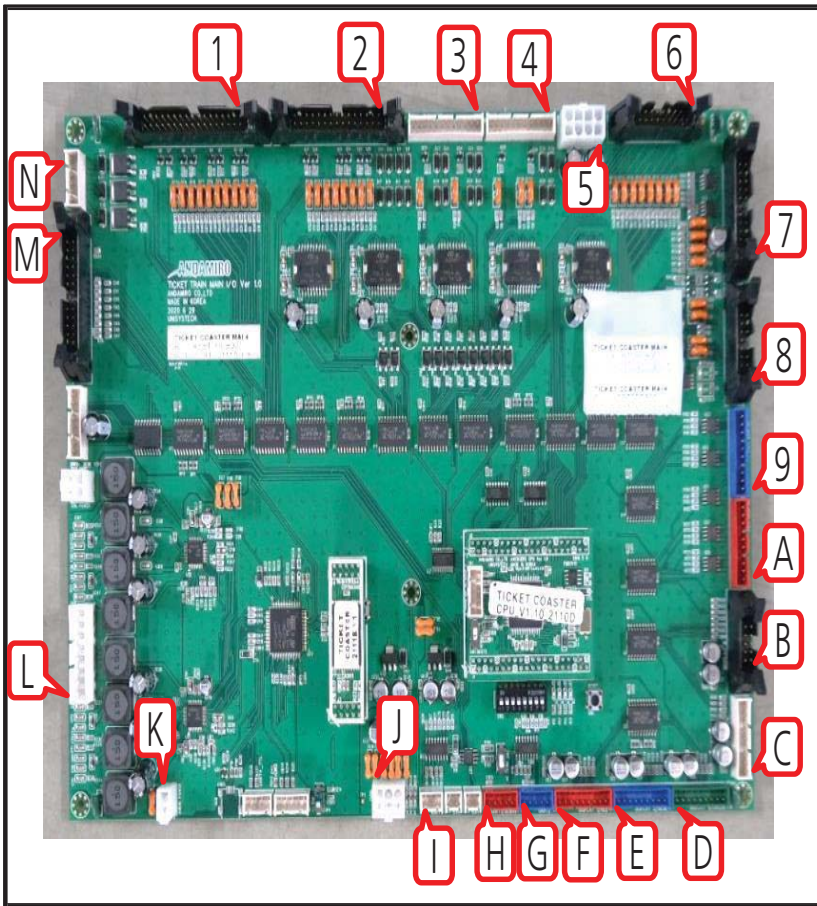

n o	FUNCTION	LOCATI ON	PIN
1	TRAIN & BALL POSITION SENSOR(SUCCESS, COLLECT)	CN5	34
2	SHOOT MOTOR & SENSOR BALL IN/OUT, RAIL SEN	CN8	30
3	BALL ELV MOT & SENSOR	CN15	12
4	TRAIN MOTOR & SENSOR	CN22	11
5	MOTOR POWER 12V	CN29	8
6	1,2P LED FAN ON/OFF SW	CN7	16
7	TICKET	CN14	20
8	COIN & BILL	CN6	14
9	2P WHITE LED, LED FAN PW	CN18	10
A	1P WHITE LED, LED FAN PW	CN16	10
B	CREDIT FND & TRAIN BALL CHEDK LED	CN13	10
C	2P BIGWIN FND	CN12	9
D	1P BIGWIN FND	CN11	9
E	2P SCORE LED	CN10	8
F	1P SCORE LED	CN9	8
G	2P VIDEO PCB	CN9	8
H	WS2813B IO PCB	CN1	5
I	1P VIDEO PCB	CN3	3
J	MAIN POWER 5V, 12V	CN28	6
K	AUDIO POWER 12V	CN27	2
L	SPEAKER	CN26	8
M	SETUP & COUNTER & VOL	CN4	26
N	CEILING LED	CN17	6

2) WS2813B IO PCB ASS'Y

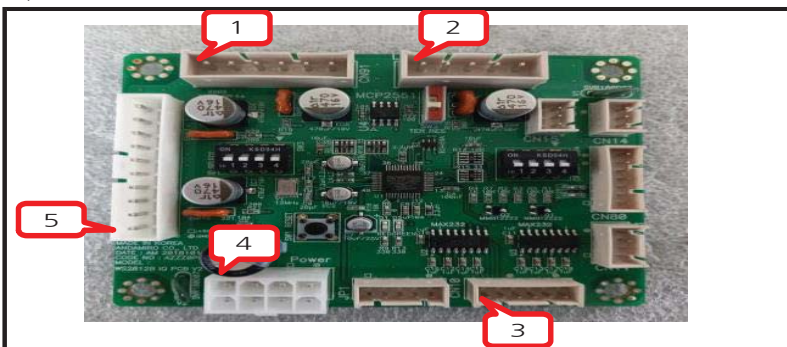

n o	FUNCTION	LOCATI ON	PIN
1	1P BOTTOM RAIL & ELV LED	LED2	6
2	1P SCORE CAP LED & UPPER RAIL LED	LED1	5
3	UART(MAIN PCB)	JP10	6
4	POWER 5V	POWER	8
5	2P BOTTOM RAIL & ELV LED 2P SCORE CAP LED & UPPER RAIL LED	LED3	10

3) VIDEO PCB ASS'Y

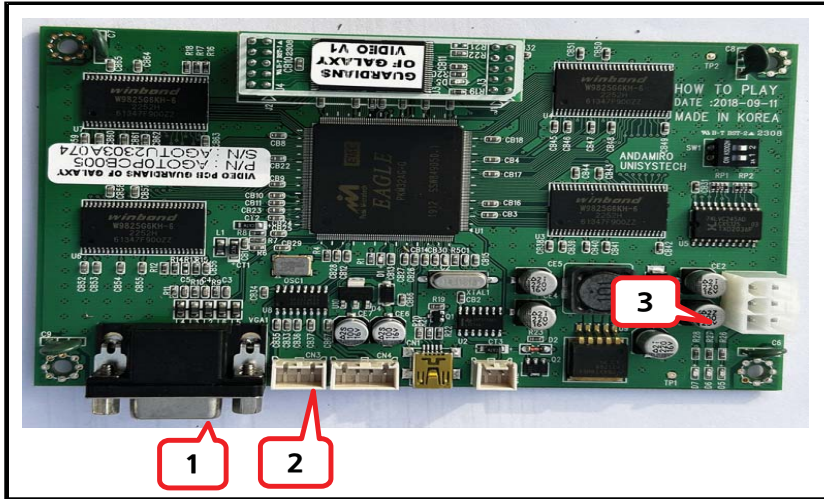

n o	FUNCTION	LOCATI ON	PIN
1	MONITOR	VGA1	15
2	MAIN PCB	CN3	3
3	POWER 5V,12V	CN5	6

4) SENSOR PCB ASS'Y

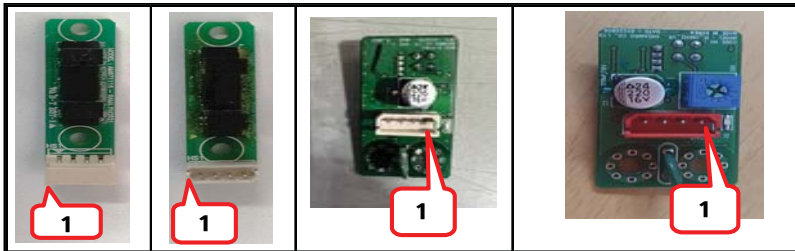

n o	FUNCTION	PIN No
1	POWER 5V	1
2	ENABLE VOLTAGE	2
3	SENSOR OUT VOLTAGE	3
4	GND	4

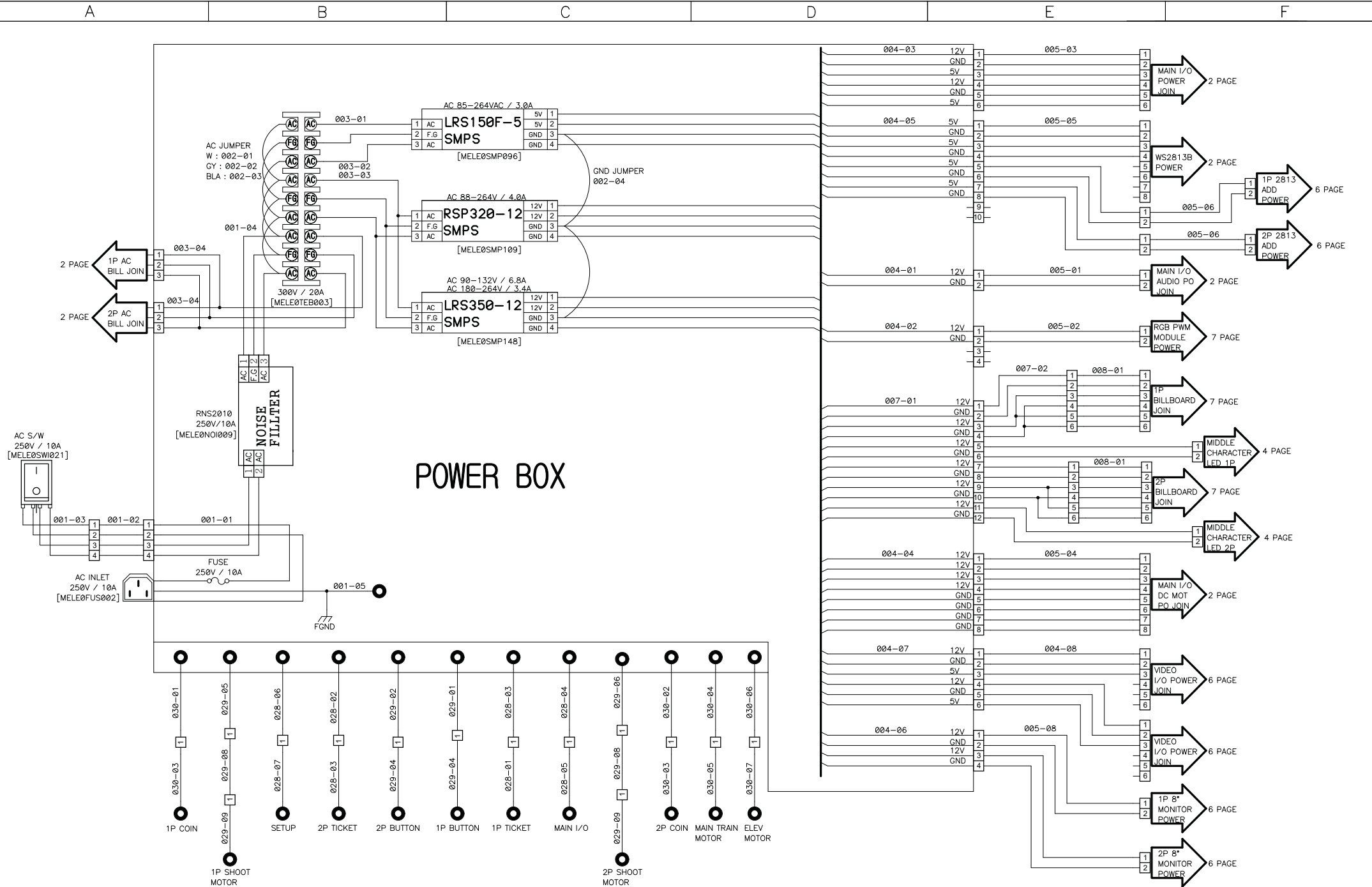

POWER BOX

REPRODUCTION, DISTRIBUTION AND UTILIZATION OF THIS DOCUMENT AS WELL AS COMMUNICATION OF ITS CONTENTS TO OTHERS WITHOUT EXPRESS AUTHORIZATION PROHIBITED. OFFENDERS WILL BE HELD LIABLE FOR THE PAYMENT OF DAMAGES. ALL RIGHT RESERVED. COPYRIGHT (c) ANDAMIRO

(복제, 배포 및 사용은 물론, 명시적 허가 없이는 라인에게 내용을 전달할 수 없으며 위반자는 손해 배상 책임을 집니다.)

DEPARTMENT	DRAWN BY	CHECKED BY	APPROVED BY	ITEM	GUARDIANS OF GALAXY
H/W	H.B.KIM			PAGE	1
				DATE	2023.04.18



MAIN PCB 1/5

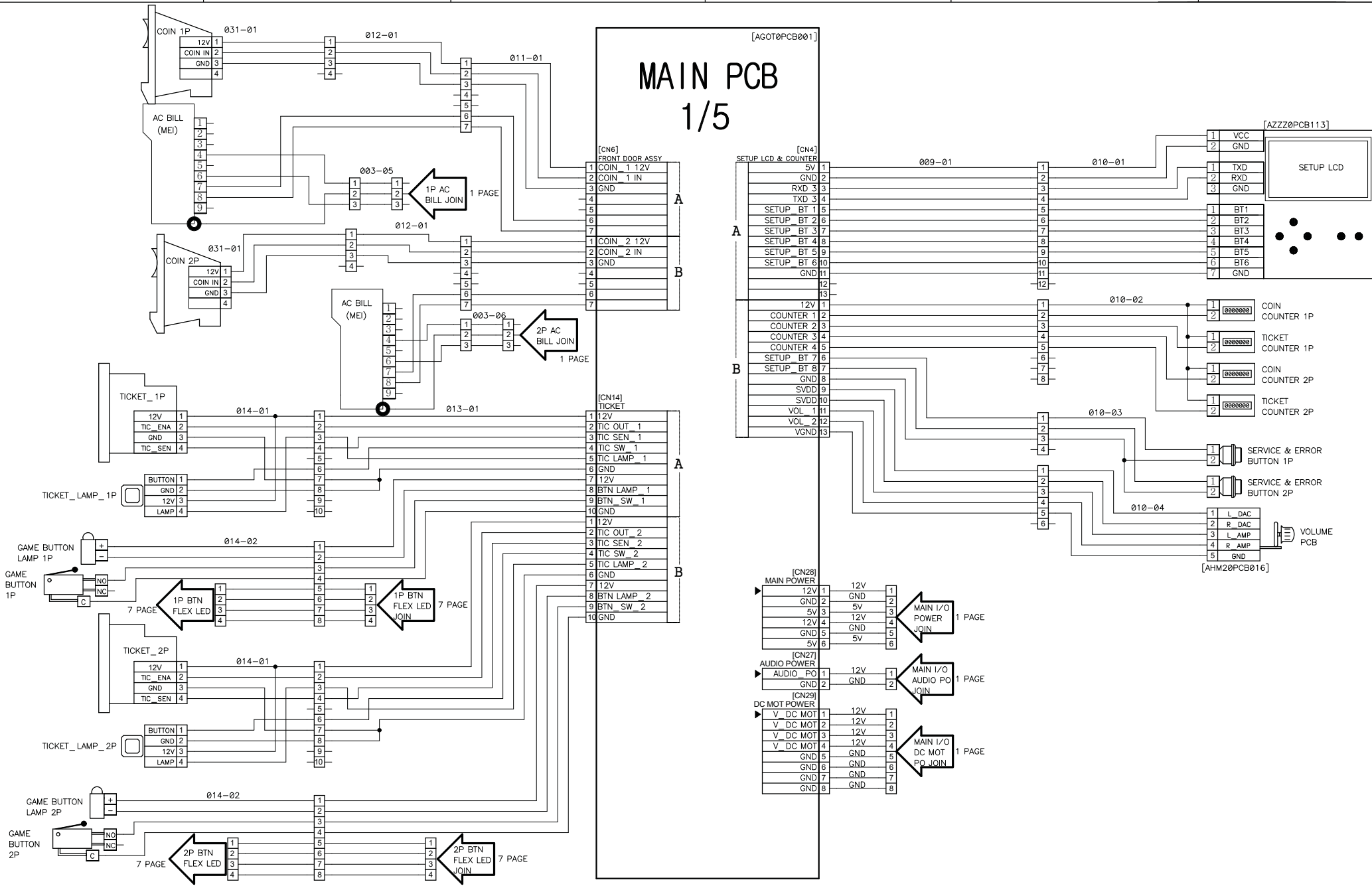

REPRODUCTION, DISTRIBUTION AND UTILIZATION OF THIS DOCUMENT AS WELL AS COMMUNICATION OF ITS CONTENTS TO OTHERS WITHOUT EXPRESS AUTHORIZATION PROHIBITED. OFFENDERS WILL BE HELD LIABLE FOR THE PAYMENT OF DAMAGES. ALL RIGHT RESERVED. COPYRIGHT (c) ANDAMIRO

(복제, 배포 및 사용은 물론, 명시적 허가 없이는 라이에게 내용을 전달할 수 없으며 위반자는 손해 배상 책임을 집니다.)

DEPARTMENT	DRAWN BY	CHECKED BY	APPROVED BY	ITEM	GUARDIANS OF GALAXY
H/W	H.B.KIM			PAGE	2
				DATE	2023.04.18



MAIN PCB 2/5

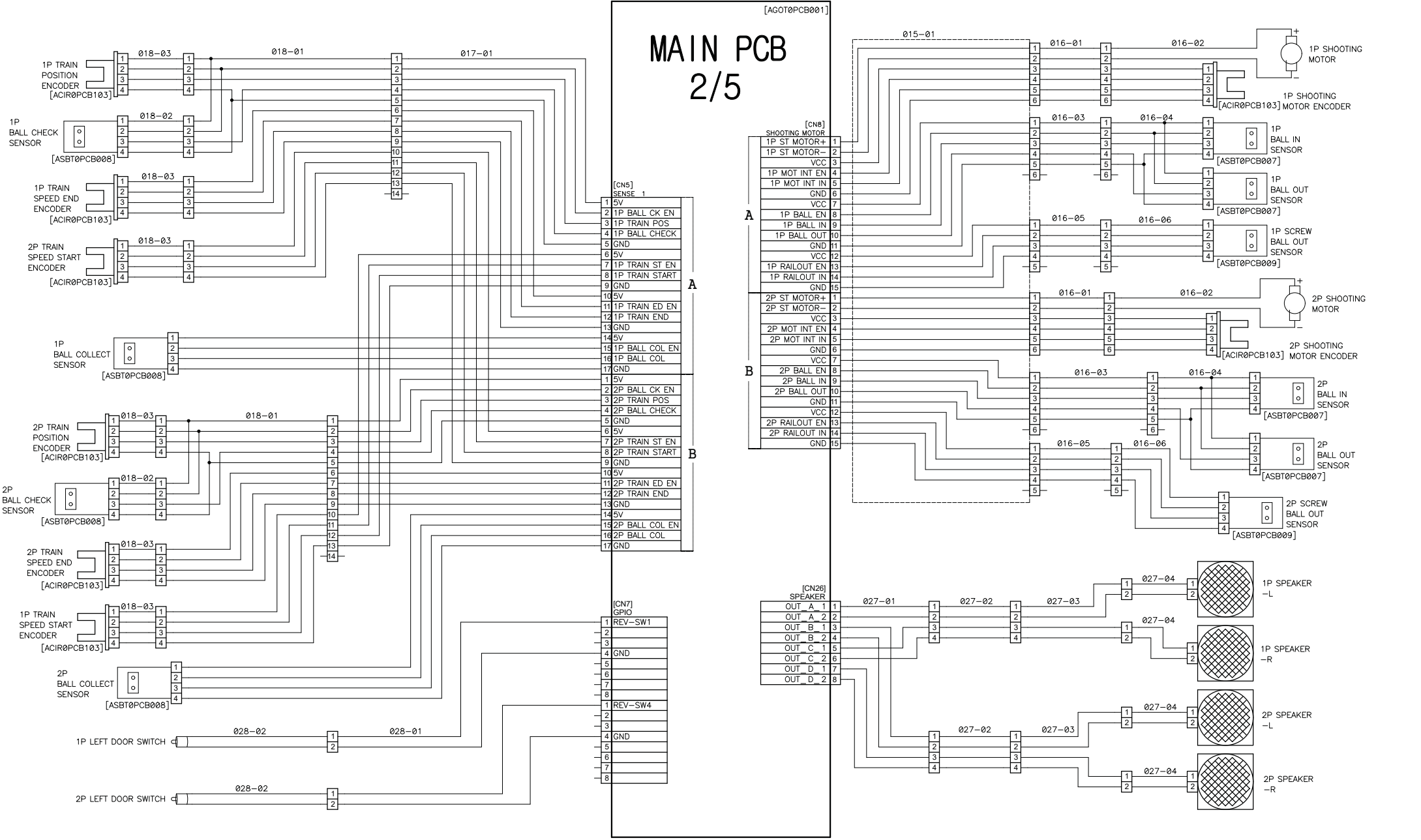

REPRODUCTION, DISTRIBUTION AND UTILIZATION OF THIS DOCUMENT AS WELL AS COMMUNICATION OF ITS CONTENTS TO OTHERS WITHOUT EXPRESS AUTHORIZATION PROHIBITED. OFFENDERS WILL BE HELD LIABLE FOR THE PAYMENT OF DAMAGES. ALL RIGHT RESERVED. COPYRIGHT (c) ANDAMIRO

(복제, 배포 및 사용은 물론, 명시적 허가 없이는 라인에게 내용을 전달할 수 없으며 위반자는 손해 배상 책임을 집니다.)

DEPARTMENT	DRAWN BY	CHECKED BY	APPROVED BY	ITEM	GUARDIANS OF GALAXY
H/W	H.B.KIM			PAGE	3
				DATE	2023.04.18



MAIN PCB 3/5

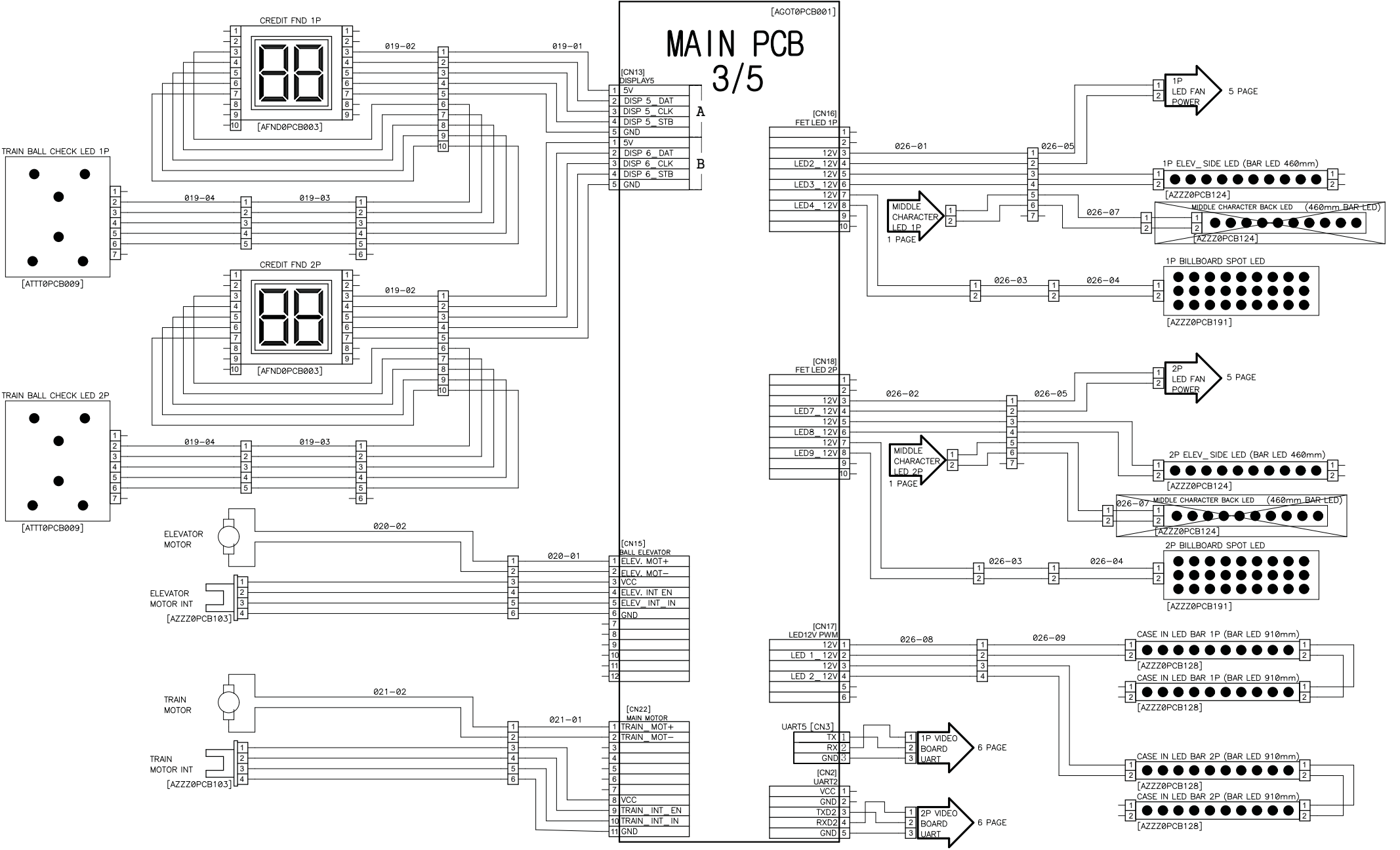

REPRODUCTION, DISTRIBUTION AND UTILIZATION OF THIS DOCUMENT AS WELL AS COMMUNICATION OF ITS CONTENTS TO OTHERS WITHOUT EXPRESS AUTHORIZATION PROHIBITED. OFFENDERS WILL BE HELD LIABLE FOR THE PAYMENT OF DAMAGES. ALL RIGHT RESERVED. COPYRIGHT (c) ANDAMIRO

(복제, 배포 및 사용은 물론, 명시적 허가 없이는 라인에게 내용을 전달할 수 없으며 위반자는 손해 배상 책임을 집니다.)

DEPARTMENT	DRAWN BY	CHECKED BY	APPROVED BY	ITEM	GUARDIANS OF GALAXY
H/W	H.B.KIM			PAGE	4
				DATE	2023.04.18



MAIN PCB 4/5

[AGOT0PCB001]

[CN9]

DISPLAY 1

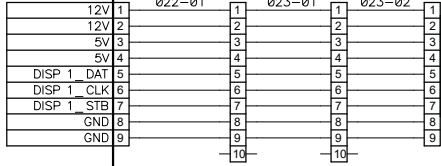

TRAIN SCORE LED

[ASBT0PCB002]

[CN10]

DISPLAY 2

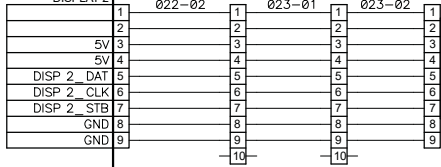

TRAIN SCORE LED

[ASBT0PCB002]

[CN11]

DISPLAY 3

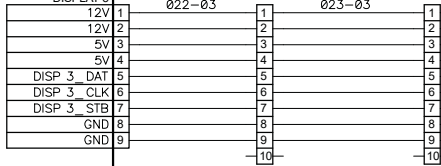

BIGWIN FND 1P



[AFND0PCB011]

[CN12]

DISPLAY 4

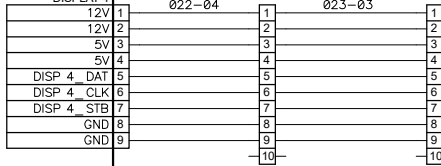

BIGWIN FND 2P

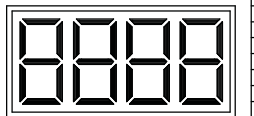

[AFND0PCB011]

1P LED FAN

2P LED FAN

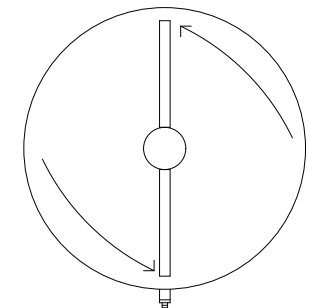
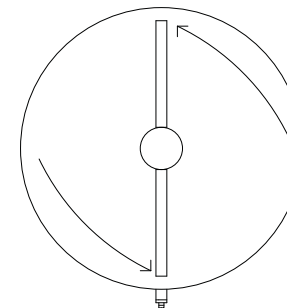

4 PAGE



026-06

4 PAGE



026-06

REPRODUCTION, DISTRIBUTION AND UTILIZATION OF THIS DOCUMENT AS WELL AS COMMUNICATION OF ITS CONTENTS TO OTHERS WITHOUT EXPRESS AUTHORIZATION PROHIBITED. OFFENDERS WILL BE HELD LIABLE FOR THE PAYMENT OF DAMAGES. ALL RIGHT RESERVED. COPYRIGHT (c) ANDAMIRO

(복제, 배포 및 사용은 물론, 명시적 허가 없이는 타인에게 내용을 전달할 수 없으며 위반자는 손해 배상 책임을 집니다.)

DEPARTMENT	DRAWN BY	CHECKED BY	APPROVED BY	ITEM	GUARDIANS OF GALAXY
H/W	H.B.KIM			PAGE	5
				DATE	2023.04.18

ANDAMIRO

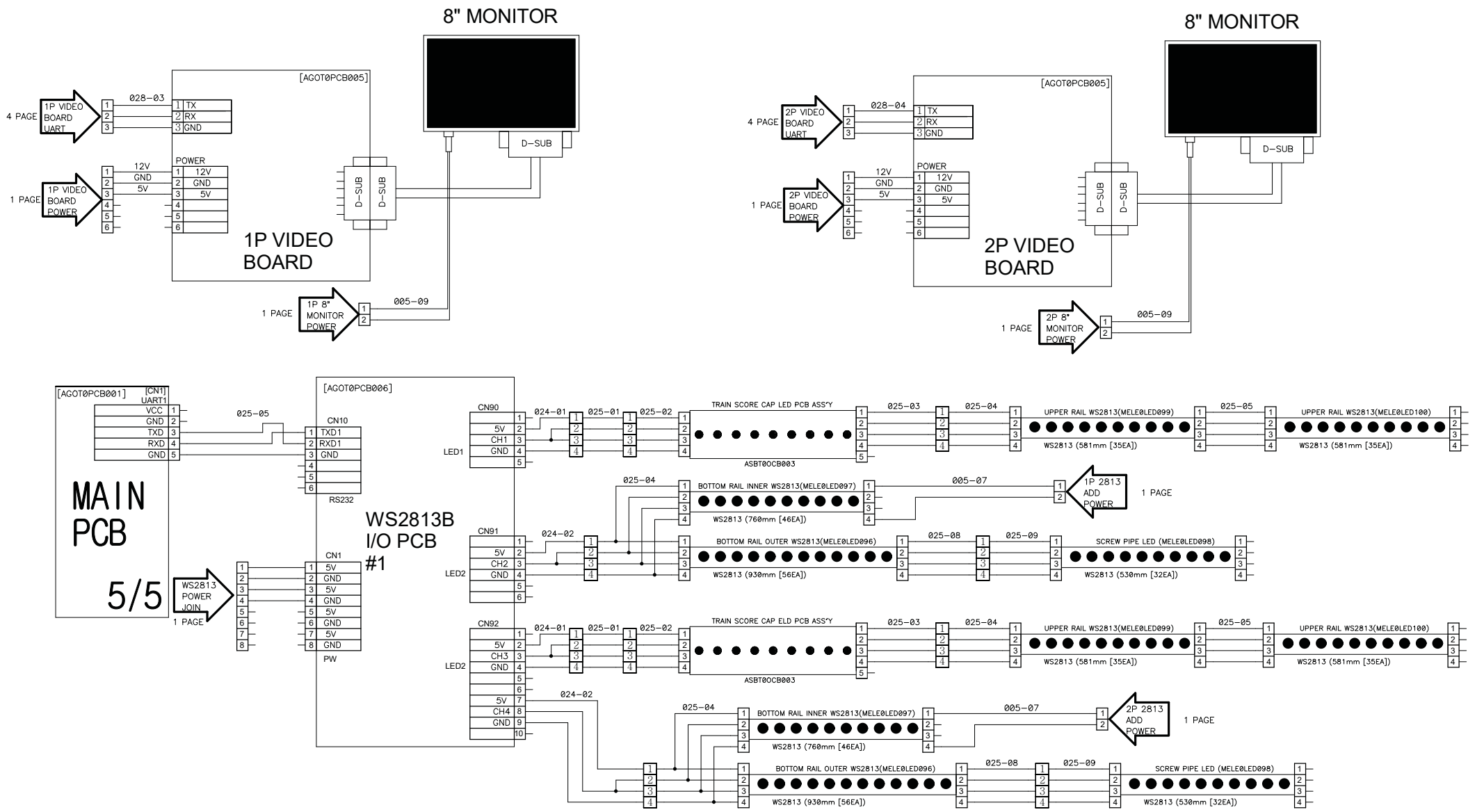

REPRODUCTION, DISTRIBUTION AND UTILIZATION OF THIS DOCUMENT AS WELL AS COMMUNICATION OF ITS CONTENTS TO OTHERS WITHOUT EXPRESS AUTHORIZATION PROHIBITED. OFFENDERS WILL BE HELD LIABLE FOR THE PAYMENT OF DAMAGES. ALL RIGHT RESERVED. COPYRIGHT (c) ANDAMIRO

(복제, 배포 및 사용은 물론, 명시적 허가 없이는 라인에게 내용을 전달할 수 없으며 위반자는 손해 배상 책임을 집니다.)

DEPARTMENT	DRAWN BY	CHECKED BY	APPROVED BY	ITEM	GUARDIANS OF GALAXY
H/W	H.B.KIM			PAGE	6
				DATE	2023.04.18



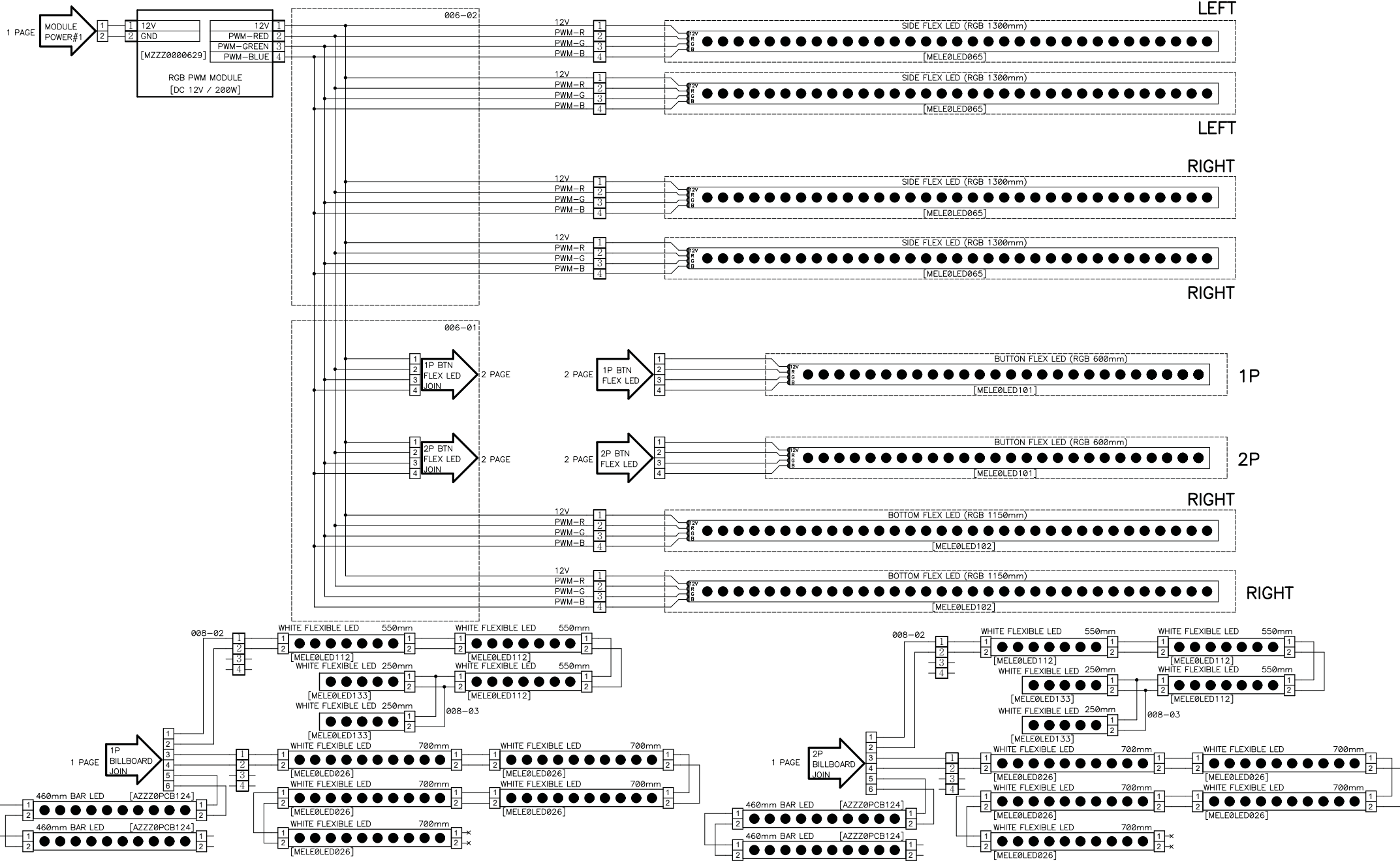

REPRODUCTION, DISTRIBUTION AND UTILIZATION OF THIS DOCUMENT AS WELL AS COMMUNICATION OF ITS CONTENTS TO OTHERS WITHOUT EXPRESS AUTHORIZATION PROHIBITED. OFFENDERS WILL BE HELD LIABLE FOR THE PAYMENT OF DAMAGES. ALL RIGHT RESERVED. COPYRIGHT (c) ANDAMIRO

(복제, 배포 및 사용은 물론, 명시적 허가 없이는 라인에게 내용을 전달할 수 없으며 위반자는 손해 배상 책임을 집니다.)

DEPARTMENT	DRAWN BY	CHECKED BY	APPROVED BY	ITEM	GUARDIANS OF GALAXY
H/W	H.B.KIM			PAGE	7
				DATE	2023.04.18



12. WARRANTY ITEM

- BILLBOARD PART

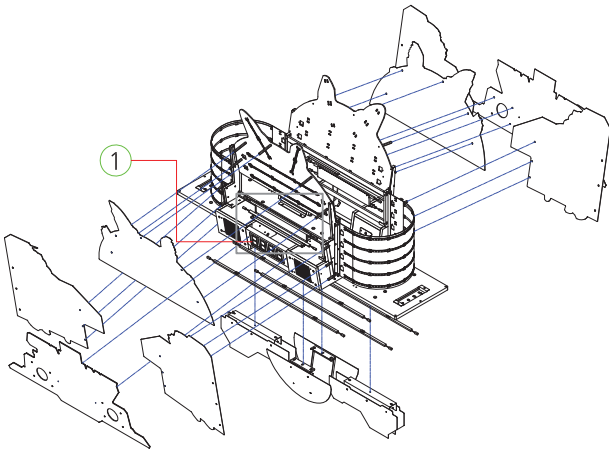

- POWER SMPS BOX PART

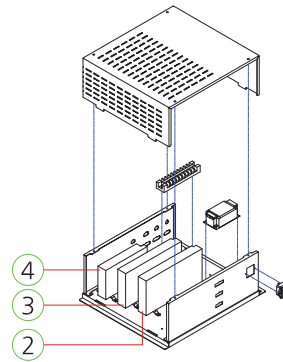

- MAIN BOARD PART

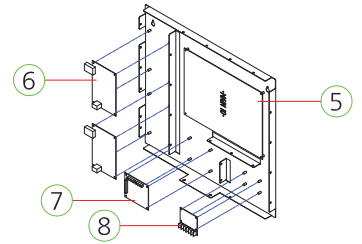

- CONTROL PANEL TOTAL PART

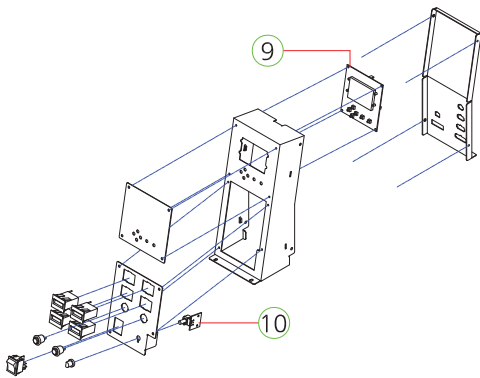

- BUTTON TOTAL PART

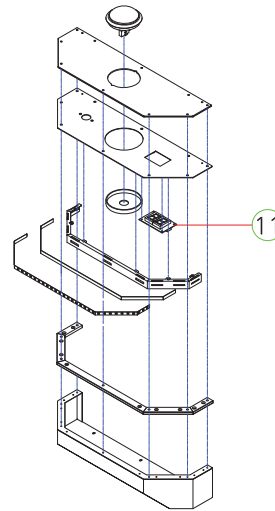

- BALL LIFT SCREW PART

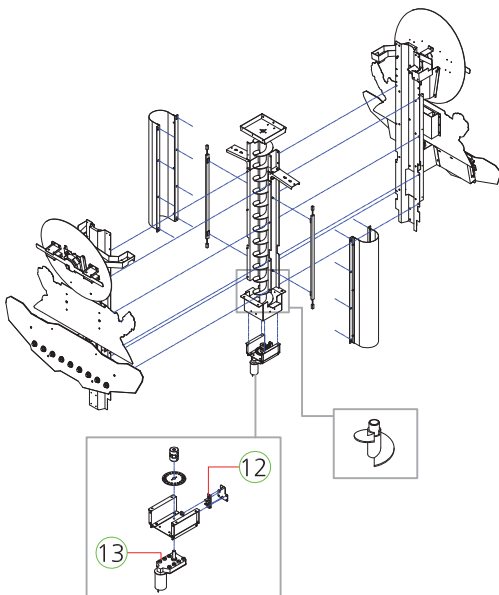

- BALL LEFT SCREW MAIN PART

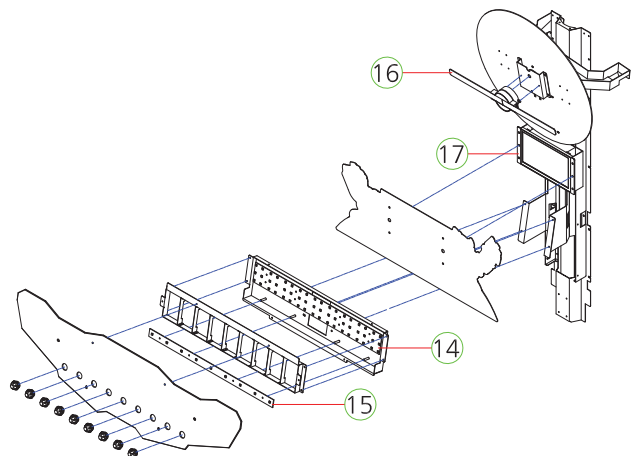

- UPPER RAIL PART

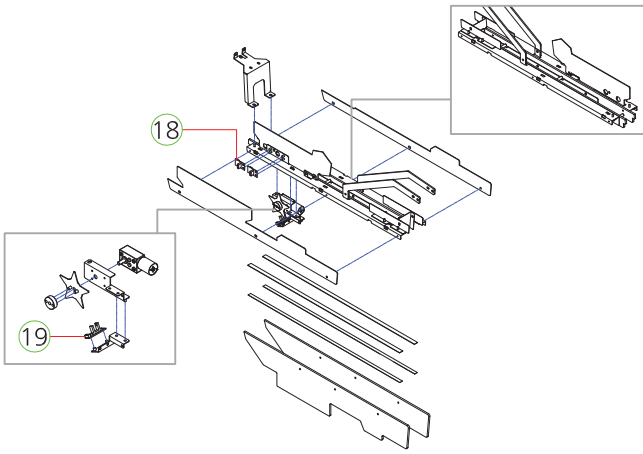

- TRAIN SIDE FENCE PART

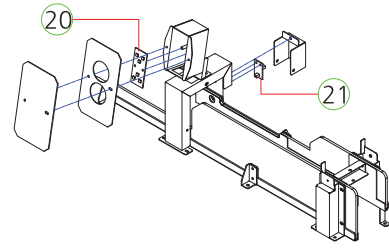

- BALL RETURN CHUTE PART-L, R

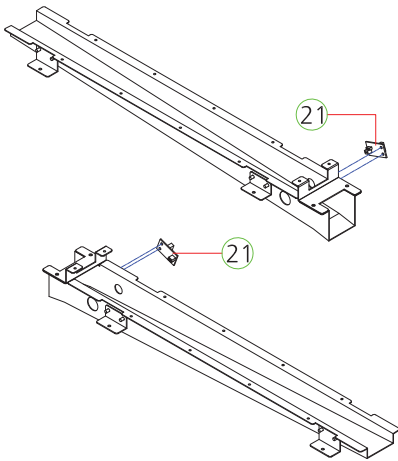

- CHAIN MAIN PLATE PART

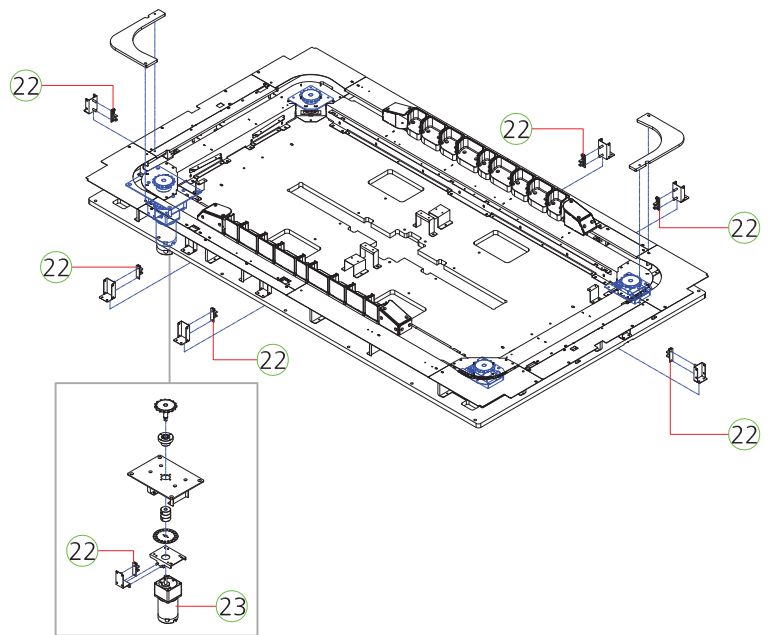

NO.	PART NAME	SPEC.	QTY	CODE NO.	WARRANTY	
					6 Month	One Year
①	FND PCB ASS'Y	6390-4(STRAIGHT)	1	AFND0PCB011		○
②	POWER SMPS	LRS-350-12V	1	MELE0SMP148		○
③	POWER SMPS	RSP-320-12V	1	MELE0SMP109		○
④	POWER SMPS	LRS-150F-5V	1	MELE0SMP096		○
⑤	MAIN IO PCB ASS'Y	WITH CPU SOUND	1	AGOT0ASS001		○
⑥	VIDEO PCB ASS'Y_EAGLE	WITH MEMORY	2	AGOT0PCB005		○
⑦	WS2812B IO PCB ASS'Y	V3_1	1	AGOT0PCB006		○
⑧	RGB PWM PCB ASS'Y	RGB_CTRL-G2GSTC0131	1	MZZZ0000629		○
⑨	SETUP LCD PCB ASS'Y	-	1	AZZZ0PCB113		○
⑩	VOLUME PCB ASS'Y	1 VOLUME	1	AHM20PCB016		○
⑪	FND PCB ASS'Y	2941-2(STRAIGHT)	1	AFND0PCB003		○
⑫	PHOTO-INT1 PCB ASS'Y	-	1	AZZZ0PCB103		○
⑬	MOTOR	KGE-0116-ND3657 U1 (12V, 43rpm)	1	MZZZ0MOT155	○	
⑭	TRAIN SCORE LED PCB ASS'Y	-	1	ASBT0PCB003		○
⑮	TRAIN SCORE CAP LED PCB ASS'Y	-	1	ASBT0PCB003		○
⑯	LED FAN_3D HOLOGRAPHIC LED FAN	-	1	MZZZ0ETC086	○	
⑰	MONITOR	8 INCH	1	MZZZ0LCD023		○
⑱	IR SENSOR PCB ASS'Y_NORMAL	SPIDER SENSE LED PCB	2	ASBT0PCB007		○
⑲	PHOTO INT-1 PCB ASS'Y	-	1	ACIROPCB011		○
⑳	TRAIN BALL CHECK UPPER LED PCB ASS'Y	-	1	ATTT0PCB009		○
㉑	IR SENSOR PCB ASS'Y_2CM	38KHZ_CONNECTOR RED	3	ASBT0PCB008		○
㉒	PHOTO-INT1 PCB ASS'Y	ANGLE TYPE	7	AZZZ0PCB103		○
㉓	MOTOR	K6DG15N	1	MZZM0MOT016	○	
	GEAR HEAD	K6G30C	1	MZZM0MOT019	○	



ANDAMIRO WARRANTY POLICY



Andamiro warrants to the original purchaser that all of its products will be free from defects in material and workmanship.

Andamiro warrants the parts from date of shipment as follows.

- **One Year Limited Warranty : Electronic Boards**
- **6 Months Limited Warranty : Moving Parts**

For any key components within the warranty period, Andamiro will repair or replace defective components free of charge.

When placing a warranty request, the customer is requested to furnish the following information:

1. Name of the game.
2. Serial Number of the game.
3. A Detailed Description of the defect/s experienced.

This warranty does not apply to the defects caused due to misuse or abuse of the product.

Any alterations made to game or game parts will void this warranty.

For warranty details on our product range please visit our website, www.andamiro.com.

ANDAMIRO CO., LTD.
www.andamiro.com





The logo for Marvel's Guardians of the Galaxy. It features the word "MARVEL" in a red box with white text at the top. Below it, the words "GUARDIANS OF THE GALAXY" are written in a large, stylized, metallic font with a 3D effect and a shadow.

ANDAMIRO CO., LTD.

TEL : 82-31-909-2123~5

[ADDRESS OFFICE] 704-1 Techno Town, 138, Ilsan-ro, Ilsandong-gu, Goyang-si,
Gyeonggi-do, Republic of Korea 10442

[FACTORY] 72 Nochemgil, Ilsan-donggu Goyang-si, Gyonggi-do, 410-834 korea

USA BRANCH

ANDAMIRO USA CORP.

TEL : 1-310-767-5800

[ADDRESS USA] 2222 Century Cir, Irving TX 75062 U.S.A

Homepage <http://www.andamiro.com/>